

# **CONTINENTAL GASOLINE/LPG ENGINES**

---

# **OPERATORS GUIDE & REPAIR MANUAL**

**T  
M  
  
S  
E  
R  
I  
E  
S**



**CORP.**

---

## FOREWORD

Good operation and a planned maintenance program as outlined in this manual are vital in obtaining maximum engine performance and long engine life. The instructions on the following pages have been written with this in mind, to give the operator a better understanding of the various problems which may arise, and the manner in which these problems can best be solved or avoided.

The operator is cautioned against the use of any parts, other than genuine Wis-Con Total Power parts, for replacement or repair. These parts have been engineered and tested for their particular job, and the use of any other parts may result in unsatisfactory performance and short engine life. Wis-Con Total Power distributors and dealers, because of their close factory relations, can render the best and most efficient service.

### **THE LIFE OF YOUR ENGINE DEPENDS ON THE CARE IT RECEIVES.**

The MODEL, SPECIFICATION and SERIAL NUMBER of your engine must be given when ordering parts. The MODEL and SPECIFICATION number are on the name plate. The SERIAL NUMBER is stamped either on the crankcase or the engine's identification tag.

Copy the MODEL, SPECIFICATION and SERIAL NUMBER in the spaces provided below so that it will be available when ordering parts.

**MODEL**

**SPECIFICATION**

**SERIAL NUMBER**

To insure prompt and accurate service, the following information must also be given:

1. State EXACTLY the quantity of each part and part number.
2. State definitely whether parts are to be shipped by express, freight or parcel post.
3. State the exact mailing address.

# **IMPORTANT**

## **READ THESE INSTRUCTIONS CAREFULLY**

All points of operation and maintenance have been covered as carefully as possible, but if further information is required, send inquiries to the factory for prompt attention.

When writing to the factory, ALWAYS GIVE THE MODEL, SPECIFICATION AND SERIAL NUMBER of the engine referred to.

### **Starting and Operating New Engines**

Careful breaking-in of a new engine will greatly increase its life and result in trouble-free operation. A factory test is not sufficient to establish the polished bearing surfaces, which are so necessary to the proper performance and long life of an engine. These can only be obtained by running a new engine carefully and under reduced loads for a short time.

- Be sure the engine is filled to the proper level with a good quality engine oil.
- For proper procedures to follow when breaking-in a new engine, see 'Testing Rebuilt Engine'.

The various bearing surfaces in a new engine have not been glazed, as they will be with continued operation, and it is in this period of "running in" that special care must be exercised, otherwise the highly desired glaze will never be obtained. A new bearing surface that has once been damaged by carelessness will be ruined forever.

# IMPORTANT SAFETY NOTICE

Proper repair is important to the safe and reliable operation of an engine. This Repair Manual outlines basic recommended procedures, some of which require special tools, devices or work methods.

Improper repair procedures can be dangerous and could result in injury or death.

## **READ AND UNDERSTAND ALL SAFETY PRECAUTIONS AND WARNINGS BEFORE PERFORMING REPAIRS ON THIS ENGINE**

Warning labels have also been put on the engines to provide instructions and identify specific hazards which, if not heeded, could cause bodily injury or death to you or other persons. These labels identify hazards which may not be apparent to a trained mechanic. There are many potential hazards for an untrained mechanic and there is no way to label the engine against all such hazards. These warnings in the Repair Manual and on the engine are identified by this symbol:



Operations that may result only in engine damage are identified in the Repair Manual by this symbol:



Wis-Con Total Power cannot anticipate every possible circumstance that might involve a potential hazard; therefore, the warnings in this manual are not all inclusive. If a procedure, tool, device or work method not specifically recommended by Wis-Con Total Power is used, you must satisfy yourself that it is safe for you and others. You should also ensure that the engine will not be damaged or made unsafe by the procedures you choose.

**IMPORTANT:** The information, specifications and illustrations in this manual are based on information that was available at the time it was published. The specifications, torques, pressures of operation, measurements, adjustments, illustrations and other items can change at any time. These changes can affect the service given to the product. Get the complete and most current information before starting any job. For parts, service, or information, contact Wis-Con Total Power, Memphis, Tennessee.

## **WARNING**

Most sub-systems used in conjunction with Wis-Con Total Power industrial engines including (but not limited to) radiators, hoses, fans, fuel tanks, fuel lines or other fuel system components, batteries, electrical connections or other electrical components, clutches, transmissions, hydraulic pumps and generators, are not supplied by Wis-Con Total Power. These items are provided by the manufacturer of the end item in which the engine is used.

Some of the dangers associated with servicing such items are generally mentioned in this manual; however, the appropriate handbooks and safety instructions provided by the manufacturer of the end item should always be consulted prior to the undertaking of any work on sub-systems attached to the engine, to avoid any hazards inherent to these sub-systems.

---

## **WARNING**

Read and observe all individual safety warnings as you use this manual to operate, service or repair your engine.

Always exercise caution whenever working with an engine or any associated system.

Injuries may be caused by lack of care when working with, or near, moving parts, hot parts, pressurized systems, electrical equipment, or fuel systems.

Always wear eye and hearing protection when working on or near engines.

Improper attire such as loose clothing, ties, rings, soft shoes or bare feet could be hazardous and should be avoided when servicing engines.

Use or service of the engine (including the use of modified parts or materials) not in accordance with manufacturer's specifications could damage your engine or cause personal injury.

---

## **WARNING**

Some equipment and materials used in the overhaul or maintenance of an engine such as machine tools, electrical equipment, compressed air, solvents, gasoline or other fuels may be dangerous and can cause injury. Always observe safety precautions.

# **CONTENTS**

## **CONTINENTAL INDUSTRIAL ENGINES**

<b>SECTION 1</b>	
General Information .....	Page 5
<b>SECTION 2</b>	
Operating Instructions .....	Page 7
<b>SECTION 3</b>	
Lubrication .....	Page 13
<b>SECTION 4</b>	
Cooling System .....	Page 15
<b>SECTION 5</b>	
Fuel Systems .....	Page 21
<b>SECTION 6</b>	
Governors .....	Page 25
<b>SECTION 7</b>	
Ignition Systems .....	Page 29
<b>SECTION 8</b>	
Preventive Maintenance .....	Page 39
<b>SECTION 9</b>	
Engine Repair and Overhaul .....	Page 47
<b>SECTION 10</b>	
Trouble Shooting .....	Page 67
<b>SECTION 11</b>	
Torque Specifications .....	Page 71
<b>INDEX</b> .....	Page 75

# **Continental Industrial Engines**

MODEL	TM20		TM27	
	METRIC	ENGLISH	METRIC	ENGLISH
No. of Cylinders	3	3	4	4
Bore & Stroke	91 x 103.2	(3.58 x 4.06)	91 x 103.2	(3.58 x 4.06)
Displacement	2.0 L	(123) CID	2.68 L	(164) CID
Compression Ratio	8.2:1	8.2:1	8.2:1	8.2:1
Max. Oil pressure*	2.8 - 4.1 Bar	(40 - 60 PSI)	2.8 - 4.1 Bar	(40 - 60 PSI)
Min. Oil Pressure (Idling)	0.5 Bar	7 PSI	0.5 Bar	7 PSI
Firing Order	1-3-2	1-3-2	1-3-4-2	1-3-4-2
Main Brg. Frt.	73 x 23.8	(2.88 x .94)	73 x 23.8	(2.88 x .94)
Main Brg. Int.	73. x 23.8	(2.88 x .94)	(2) 73 x 23.8	(2.88 x .94)
Main Brg. Thrust	73 x 31.8	(2.88 x 1.25)	73 x 31.8	(2.88 x 1.25)
Main Brg. Rear	73 x 23.8	(2.88 x .94)	73 x 23.8	(2.88 x .94)
Conn. Rod Brg.	49.2 x 24.5	(1.94 x .96)	49.2 x 24.5	(1.94 x .96)
Oil Capacity				
Crankcase	4.73 L	(5 quarts)	5.7 L	(6 quarts)
Filter	.95 L	(1 quart)	.95 L	(1 quart)
Total	5.68 L	(6 quarts)	6.6.5 L	(7 quarts)
Valve Clearance				
Intake	.36	(.014)	.36	(.014)
Exhaust	.46	(.018)	.46	(.018)
Water Capacity				
Engine	2.84 L	(3 quarts)	3.6 L	(3.8 quarts)
Weight (approx.) (with accessories)	227 kg	(500 lbs.)	243 kg	(536 lbs.)
Spark Plug Gap	0.8	(.032)	0.8	(.032)

\* Higher oil pressure may be experienced during cold starts.

## INFORMATION FOR ORDERING PARTS

When ordering parts, refer to the engine name plate attached to side of the cylinder block, which lists the model and serial number. In most cases a specifi-

cation number is listed. This data is of vital importance in obtaining the correct parts: always include this information on your parts order.



Typical Nameplate

# Section 1 - General Information

Overhead valve engine design provides the highest power output and operating efficiency.

The valves are located in the cylinder head, which permits larger valves to assure improved combustion and engine output. The ease of servicing the valves coupled with the improved cooling of the exhaust valves and ports are important features of engine maintenance. Overhead valve design minimizes the tendency to impose thermal deformation on the cylinder structure.

Engines of this type being narrower in frontal elevation, lend themselves to a more favorable arrangement of the engine accessories, such as carburetor, starter, alternator and filters for industrial applications.

## CONTINENTAL OVERHEAD VALVE ENGINE

The Continental Overhead Valve Engines range in size from 1.35L (82) to 2.68L (164) cubic inches displacement.

The combustion chamber design has been tailored for the required turbulence, charge flow and burning characteristics to provide dependable and economical heavy duty service.

Some of the principal design features are:

1. **Individual Porting** — of the intake manifold whereby each cylinder is fed with the fuel-air mixture individually and not influenced by other cylinders of the engine.

This is accomplished by casting the cylinder head with individual intake valve passages for each cylinder and connecting these passages to an intake manifold which also has individualized passages for each cylinder.

This equal distribution results in maximum power, smooth operation, easy starting and longer engine life.

2. **Water Jackets** — completely surround all cylinder bores to a depth sufficient to cover the hot piston ring travel, resulting in minimum bore distortion for good oil control yet maintaining low heat rejection to the coolant.

**CHOICE OF FUELS** — Continental Industrial Engines have been tailored for heavy duty operation for use with gasoline - LPG - natural gas and non-leaded fuels that meet a minimum octane of 85 motor method.

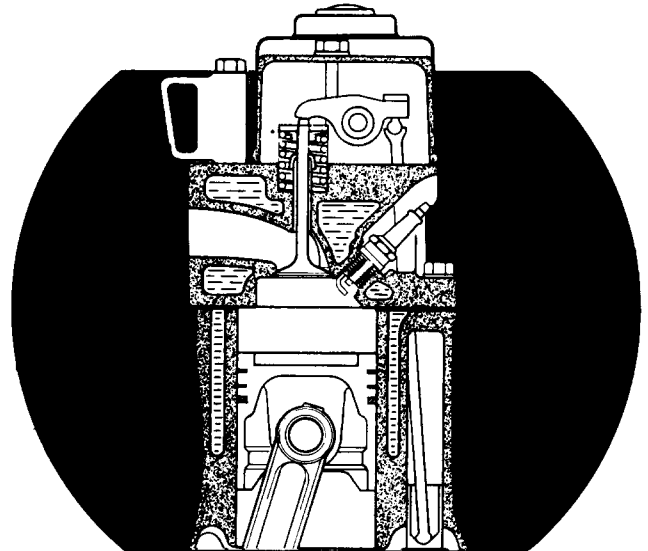

OHV Design

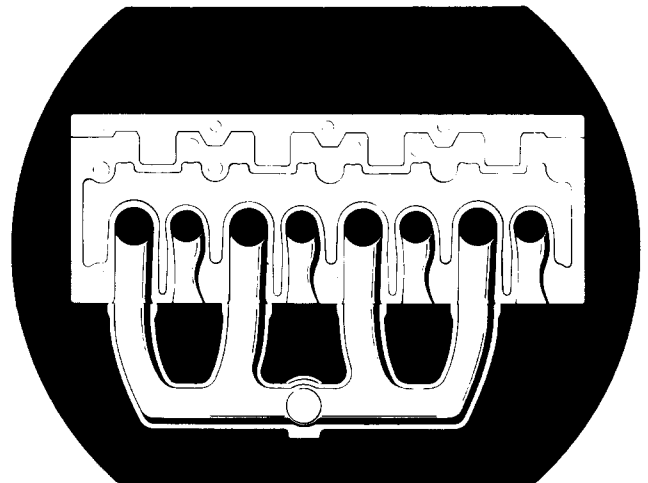

Individual Porting



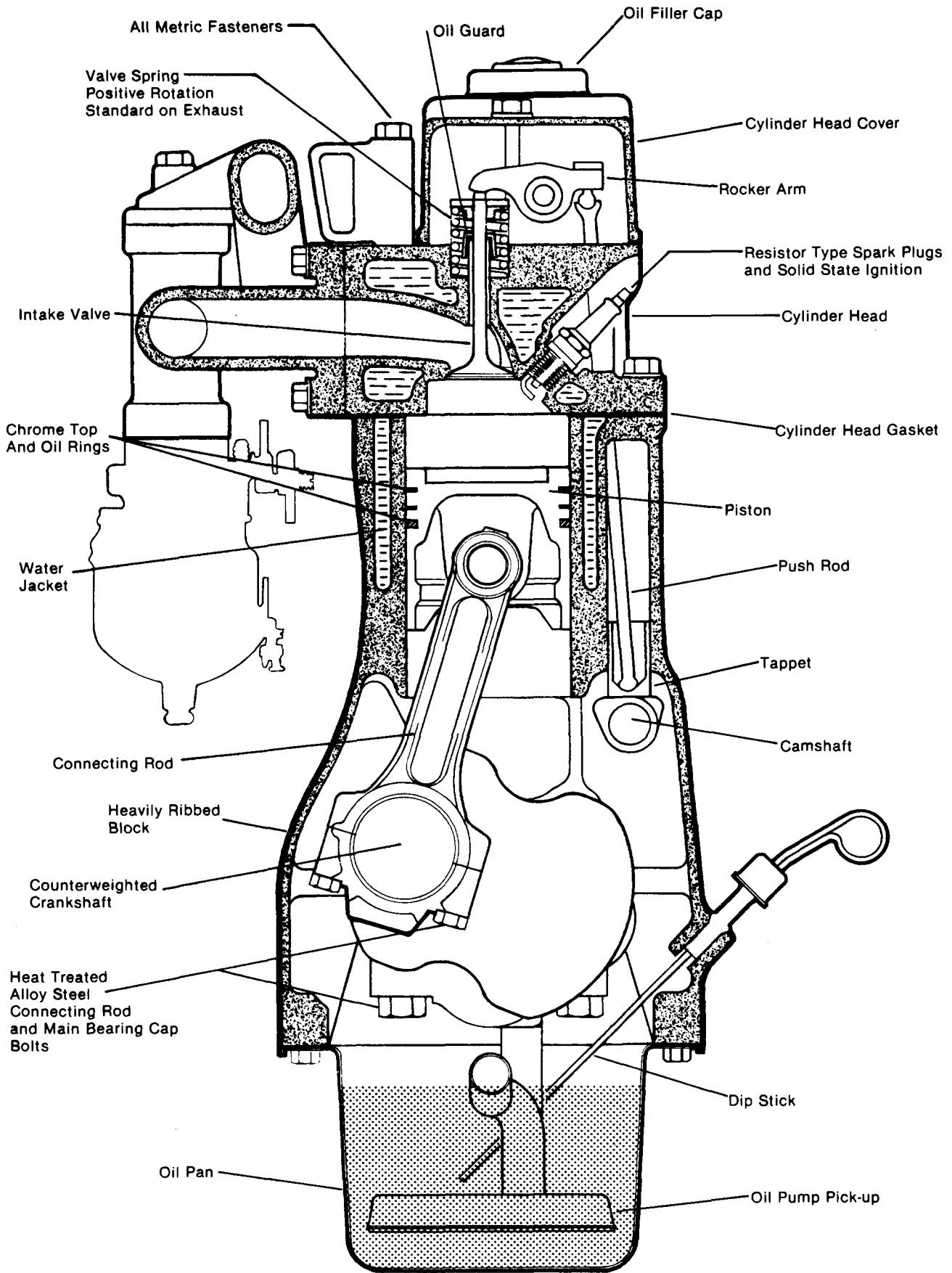

Cross section of a typical Continental Overhead Valve Industrial Engine

# Section 2 - Operating Instructions

The person operating the engine naturally assumes responsibility for its care while it is being operated. This is a very important responsibility since the care and attention given the engine goes a long way in determining how long a period it will operate satisfactorily before having to be shut down for repairs.

The operating and preventive maintenance instructions for the Overhead Valve type engines are simple and should be followed without deviation.

The entire aim in setting forth these instructions is to give you a benefit of the knowledge and experience gained over a long period of collaboration between Engineering Research and Field Service.

## PREPARATION OF A NEW ENGINE FOR OPERATION

Before placing a new engine in operation, it must be thoroughly inspected for external damage and particular attention paid to the following items:

- 1. Inspect Engine Hold Down Bolts** — To make certain that they are firmly set.
- 2. Close water drain cock** — on the side of the block. (In some cases, this may be a pipe plug.) Fill radiator and water jacket with coolant (see Cooling System section 4).

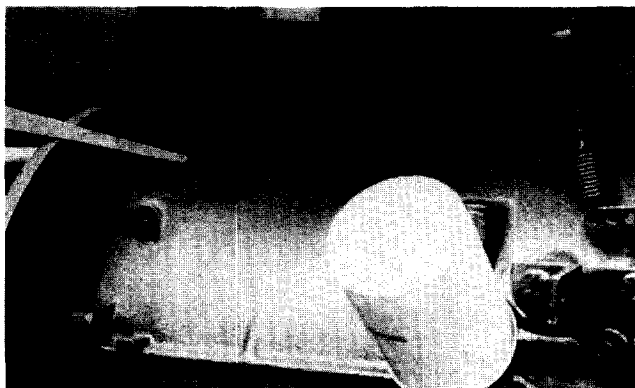

Water Drain Cock

- 3. Fill Crankcase with oil** — Use the oil recommended for the ambient temperature (see chart on page 14).

- 4. Engine Accessories** — see that all points requiring lubrication are properly lubricated.



Radiator Coolant Inlet

- 5. Electrical Connections** — Check storage battery terminals and all electrical connections. Check each spark plug wire for tightness.

## WARNING

Stop engine before checking battery terminals or electrical connections. Do not hold ignition wires with bare hands since shocks or other injuries can result. Sparks or flames near a battery could cause an explosion or fire. Battery acid can cause corrosive burns. Always wear eye protection. Use of jumper cables or battery charging should be done only as directed by manufacturers safety instructions.

Read and observe safety warnings on pages 1 and 2.

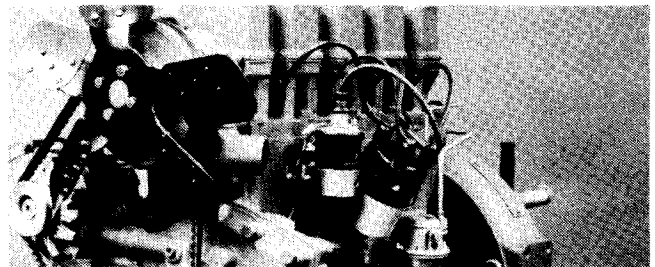

Electrical Connections

## STARTING THE ENGINE

## WARNING

Bodily injury or death may result to individuals during operation of an engine within any enclosure not adequately or properly ventilated. Engine operation in any enclosure requires adequate and proper ventilation to avoid asphyxiation or other interruption of normal breathing, to supply sufficient air to cool the engine, provide air to mix with fuel and to carry away heated air from the building.

Read and observe safety warnings on pages 1 and 2.

Normally check daily preventive maintenance schedule before starting. — (See section 8)

1. **Disengage Power Take-Off** — (if equipped) Starting engine under load throws overload on starter and battery.
2. **Open Throttle Control** about 1/3 open
3. **Turn on Ignition Switch**
4. **Pull Out Choke** (if manually operated) But avoid flooding the engine. Operate the engine without choking as soon after starting as possible.

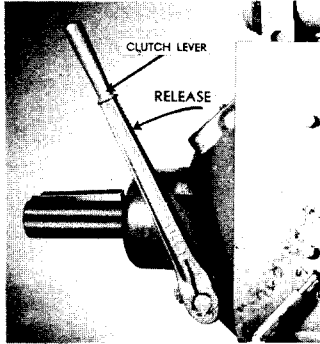

Power Take-off

5. **Push Starter Button In** — Keep on until engine starts; but not longer than 15 seconds at a time.
6. **Warm-up Before Applying Load** — Idle the engine at 600-1000 R.P.M. for a few minutes to circulate and warm oil — then increase the speed to approximately half throttle until the engine water reaches 100° F. This procedure will prolong the engine life.
7. **Check Oil Pressure**

MODEL	OIL PRESSURE*
TM	2.8 - 4.1 Bar (40 - 60 PSI)

\*Higher oil pressure may be experienced during cold starts.

8. **Check Water Temperature** (See Instrument Panel.)

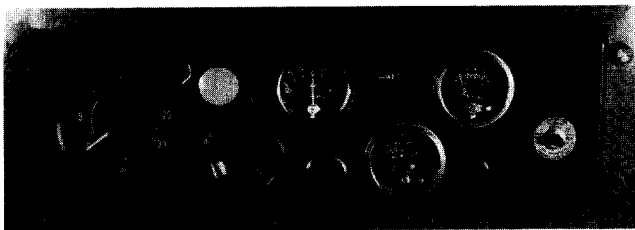

Typical Instrument Panel

9. **Check Ignition Timing** (refer to pages 33 and 34 Distributor Ignition Timing)
10. **CAUTION:** After starting new engine — run it at idle for 5 minutes, then stop engine and recheck oil level in crankcase — then bring oil level to high mark on dipstick.

**IMPORTANT!** Breaking in a new or rebuilt engine — for peak performance and economical operation, the following adjustments should be made at end of first 50 hrs. operation.

1. Torque down cylinder head cap screws to specification.
2. Adjust valve tappets to specified clearances.
3. Adjust idle mixture and idle speed to 400-600 R.P.M. (800-1000 R.P.M. on the 2-cylinder engine).

## WARM UP NEW ENGINES

When new engines in distributors or dealers stock, showrooms, etc. are started up for any reason, *they should be brought up to operating temperature in order to eliminate all condensation before stopping.*

If they are stopped while still cold, condensation will settle on valve stems and guides, as well as other moving parts, and rust and sludge will form. Soon valves, rings, etc. will be stuck by this rusting and sludging action.

Engine should be operated long enough to bring oil and water temperature to normal operating temperature; *be sure breather or ventilation system is open so vapor can be expelled.*

## SPEED CONTROL

The throttle control is used to close the carburetor butterfly valve to limit engine speed below governed speed.

Engines are provided with a mechanical, electronic or velocity governor set to maintain the load and speed specified when the engine is ordered. If individual requirements necessitate a change of governed speed — reset governor as outlined under "Governor adjustment", but do not exceed manufacturer's recommended maximum speed, since this has been worked out with the end product requirements in mind.

When extended periods occur between the applications of load, it is recommended that the engine be throttled down to minimum idling speed or, if the intervals are usually long, that it be shut down.

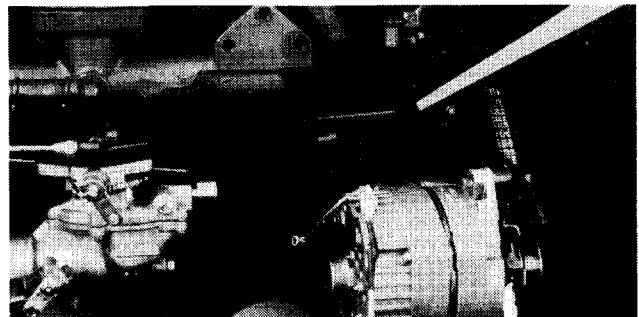

Governor Lever  
(This may vary with the application)

## STOPPING THE ENGINE

1. Disengage Power Take-Off
2. Reduce engine Speed to Idle — if hot, run engine at idle for several minutes to cool.
3. Turn off Ignition Switch — If engine continues to run due to high combustion chamber

temperatures, either continue idling to further cool or shut off fuel supply.

**CAUTION: NEVER PULL OUT CHOKE WHEN STOPPING ENGINE — BECAUSE RAW GASOLINE WILL WASH LUBRICANT FROM CYLINDER WALLS.**

## 11 "MUSTS" FOR YOUR ENGINES

1. OIL PRESSURE - should be up to recommended pressure at operating speed and over 0.5 Bar (7 PSI) at idle (400-600 R.P.M.) and (800-1000 R.P.M. on the 2-cylinder engine).

2. AMMETER - should register "Charging" at all times engine is running. (A voltage regulator may limit it to a very low reading).

3. WATER TEMPERATURE - normal operation 81°C-96°C (178-205° F.). pressure cap determines higher temperatures. Overheating is detected by loss of coolant. "FREQUENT READINGS OF GAUGE SHOULD BECOME A HABIT".

4. MUFFLER RESTRICTION - should not exceed 508mm (20") water or 38mm (1-1/2") Mercury. Inspect mufflers periodically for restrictions to prevent burned valves.

5. CLEAN AND SERVICE AIR CLEANER - as recommended to maintain its efficiency.

6. WHEN ENGINE IS OVERHEATED - do not add water - allow engine to cool so as to prevent cracking the cylinder block or cylinder head.

7. ENGINE LOAD INDICATION - a manifold vacuum of 127mm (5 inches) of Mercury indicates the recommended continuous full load operation and a vacuum of 460-500mm (18-20 inches) of Mercury indicates normal idling vacuum. Between full

load and idling, vacuum gauge readings may be used to approximate the percent loss. Below 127mm (5") of Mercury indicates engine is overloaded for continuous duty.

8. AVOID COLD-SLUDGE CONDENSATION - by protecting unit to maintain crankcase temperature over 57°C (135°F.). Use a proper temperature range thermostat and warm engine up thoroughly.

9. BREAKING IN A NEW OR REBUILT ENGINE - for peak performance and economical operation, the following adjustments should be made at end of first day's operation;

1. Torque down cylinder head to specifications.
2. Adjust valve tappets to specified clearances.
3. Adjust idle mixture and idle speed to 400-600 R.P.M. (800-1000 R.P.M. on the 2-cylinder engine).

10. FOLLOW PREVENTIVE MAINTENANCE SCHEDULES RECOMMENDED - this will avoid troubles which might cause expensive breakdowns and maintain your engine for dependable and economical operation.

11. IDLING ENGINE - slow engine to low idle (600 R.P.M., depending on the application) for about 5 minutes, after each operating period, before stopping - too rapid cooling down may cause distortion. DO NOT RUN AT LOW IDLE FOR PROLONGED PERIODS.

## COLD WEATHER OPERATION

*Battery condition is very important for proper starting.*

The oil used during cold weather should have a cold test below the lowest anticipated temperatures that will be encountered during its use. The multigrade lubricating oils 5W-20 and 10W-30 are ideal for cold starting with its reduced initial drag until warmed up, when they assume the characteristics of the heavier oil.

Sludge formation at low temperatures is a close second to dirt in causing engine damage and wear. This is formed by the piston combustion gases mixing with the fine oil mist in the crankcase and condensing on a cold surface. This condensation forms both a sulphuric and sulphurous acid which combines with the oil to become a highly injurious sludge. This dew point is about 57°C (135°F.) — when crankcase

temperatures are higher, the contaminated gases remain in gaseous form and the engine operates clean as long as breather system is kept clean — however temperatures below this will result in injurious sludge formation. It is vitally important therefore to maintain oil and crankcase temperatures above 57°C (135°F.) as shown on the following chart:

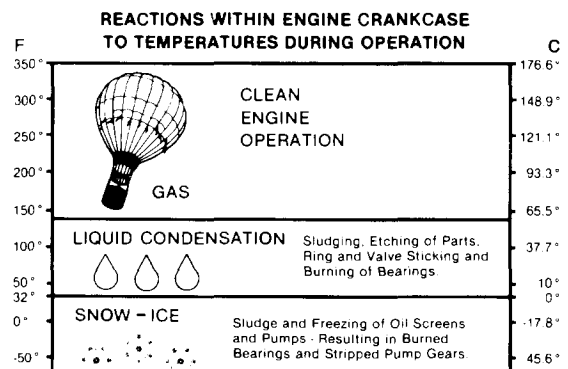

*When sludging conditions prevail, the oil should be examined daily and changed as it may freeze, or clog the inlet strainer and cause bearing or oil pump failures.*

**High Altitude Operation** — High Altitude operation reduces the power output approximately 3½ % for every 305 meters (1000 feet) of altitude above sea level.

**High Temperature Operation** — for every 5°C (10°F.) above 29.4°C (85°F.) carburetor air temperature — a power loss of 1% results.

## ENGINE PREPARATION FOR WINTER USE

More than 90% of the hard starting complaints in cold weather are the direct result of inadequate attention to preparation for winter use and proper maintenance. An engine not properly prepared and "out of tune" requires more cranking energy and time, which puts a heavy load on batteries. So, invariably, batteries run down and the engine is blamed for hard starting. Putting your engine in proper condition and keeping it that way pays big dividends by reducing costly down time.

Use the checklist which follows to get your engine ready for winter. Then use the winter maintenance schedule to keep it in peak operating condition during the winter months.

## CHECKLIST

### **WARNING**

**Stop engine before checking battery terminals or electrical connections. Do not hold ignition wires with bare hands since shocks or other injuries can result. Sparks or flames near a battery could cause an explosion or fire. Battery acid can cause corrosive burns. Always wear eye protection. Use of jumper cables or battery charging should be done only as directed by manufacturers safety instructions.**

**Read and observe safety warnings on pages 1 and 2.**

### 1. ELECTRICAL SYSTEM

- A. Battery - replenish water and test for condition and state of charge. Replace if required.
- B. Wiring - check battery cables, connections and other wiring. Be sure connections are clean and tight and that cables and wiring insulation are in good condition.
- C. Alternator and regulator - run the engine and check the ammeter to be sure the alternator is charging and the regulator is functioning properly. Check and adjust alternator belt tension.

- D. The standard overhead valve engine uses solid state ignition with no points to clean or adjust. Clean, regap, or replace spark plugs as required. Check ignition harness for loose connections and frayed insulation, repairing or replacing as required. Check and clean the inside and outside of the distributor cap. Remove the high tension lead from the coil tower and clean the coil tower. Be sure all weather-protective rubber caps are in good condition and firmly in place.

### 2. COOLING SYSTEM

#### **WARNING**

**If the coolant is hot or if the engine has been running, loosen the pressure cap to the first stop and let the pressure out of the cooling system before removing the radiator cap.**

**Read and observe safety warnings on pages 1 and 2.**

- A. Check radiator, hoses and engine for water leaks. Tighten hose clamps, repair leaks and install antifreeze to the level required for winter protection.

### 3. LUBRICATION SYSTEM

- A. Drain oil and change filter. Add oil of the proper winter grade.
- B. If the unit employs a fluid coupling, torque converter, transmission or differential, check the instruction manuals for the proper winter grade lubricant and install it.

### 4. FUEL SYSTEM

- A. Check the throttle and choke controls for satisfactory operation and adjust as required.
- B. Check the carburetor and clean as required. Check and adjust the carburetor idle speed control.

### 5. EXHAUST SYSTEM

- A. Check the rain cap, if supplied, for proper operation and repair as required.

### 6. INTAKE AIR SYSTEM

- A. Be sure all hoses and clamps are properly seated and tight.
- B. Check instructions on the oil bath air cleaner. Clean and refill with the recommended winter grade of oil. Service dry type air cleaner as specified.

## 7. MISCELLANEOUS

- A. If the engine is equipped with a preheater or cold starting aid, check the operation according to instructions, repair or adjust as required.
- B. Check and adjust tappets.

## WINTER MAINTENANCE

1. Perform maintenance in accordance with instruction manuals.
2. Change oil at least every thirty days.
3. If unit is only used for short periods and does not get thoroughly warm, operate it for at least an hour once a week to get it thoroughly warm. This will avoid excessive sludge in the oil and reduce dilution of oil with raw fuel in the crankcase.

## PREPARATION OF ENGINE FOR SEASONAL STORAGE

(90 DAYS TO 6 MONTHS)

**CAUTION:** Before starting the processing, engine must be cooled down to the surrounding temperature, since oil will adhere much better to cold metal surfaces.

1. **Drain Oil from Oil Pan** — and replace drain plug.
2. **Refill Oil Pan** — with high grade SAE 30 or 40 engine oil to 1/2 its normal capacity.
3. **Start Engine** — and run above 600 R.P.M. for 2 minutes to complete oil distribution on all surfaces — **Do Not Run Longer Than 2 Minutes.**
4. **Stop Engine** — Remove all Spark Plugs.
5. **Pour Approximately 90 Grams (3 Ounces) of SAE 30 or 40 Engine Oil** — into each Spark Plug Hole.
6. **With Ignition Cut Off — Crank Engine with Starter** — for at least a dozen revolutions to distribute this oil over the cylinder walls and valve mechanism.
7. **Drain Oil from Pan and Reassemble Plug.**
8. **Drain Cooling System and Close Drain Cocks.**



## WARNING

Smoking or open flame should be avoided any time the fuel system is being repaired or serviced. The area should be properly ventilated. Improper handling of fuel could result in an explosion or fire causing bodily injury to yourself or others.

Read and observe safety warnings on pages 1 and 2.

9. **Drain All Gasoline** — from tanks, lines and carburetor bowl.

10. **Replace All Spark Plugs.**

11. **Seal Air Cleaner Inlet—Exhaust Outlet—** with weather proof adhesive tape.

12. **Check Oil Filler Cap — Gas Tank Cap and Radiator Cap to make certain they are securely in place.**

**Note:** If Mil-L21260 No. 30 oil is available, substitute in Steps 2 and 5.

## SHORT TERM STORAGE

(30 TO 90 DAYS)

If the shut down period is to be over 30 days duration, the following instructions should be adhered to:

1. Stop engine, remove spark plugs.
2. Pour approximately 90 grams (3 ounces) clean engine oil in each spark plug hole.
3. With ignition cut off, crank engine with starter at least a dozen revolutions to distribute this oil over the cylinder walls and valve mechanism.
4. Replace all spark plugs.
5. Remove drain plug from carburetor bowl, and drain fuel.
6. Replace drain plugs.

**Caution:** Gasoline evaporates if left in carburetor for long periods. This evaporation of gasoline will leave a gum and varnish coating over jets and moving parts: when engine is started up again, you may have flooding or poor operation from carburetor.



# Section 3 - Lubrication

## ENGINE LUBRICATION SYSTEM

Continental Industrial engines have full pressure lubrication to all main, connecting rod and camshaft bearings as well as rocker arms and timing gears. Tappets are splash lubricated by overhead oil return.

### OIL PUMP

On all engines, a large capacity Gerotor type oil pump is driven off the crankshaft and protected by a large screen inlet.

An adjustable by-pass valve maintains suitable oil pressure from idle to maximum speed automatically.

Refer to page 4 for complete oil pressure figures.

**CAUTION:** If the oil pressure is erratic or falls below these limits, stop the engine IMMEDIATELY and find the cause of the trouble. Refer to trouble shooting section for this information.

A full flow oil filter is provided to remove dirt and foreign elements from the oil. The removal of grit, sludge and foreign particles causes filter elements to clog and become ineffective unless they are normally replaced every 100 hours or more often if conditions require.

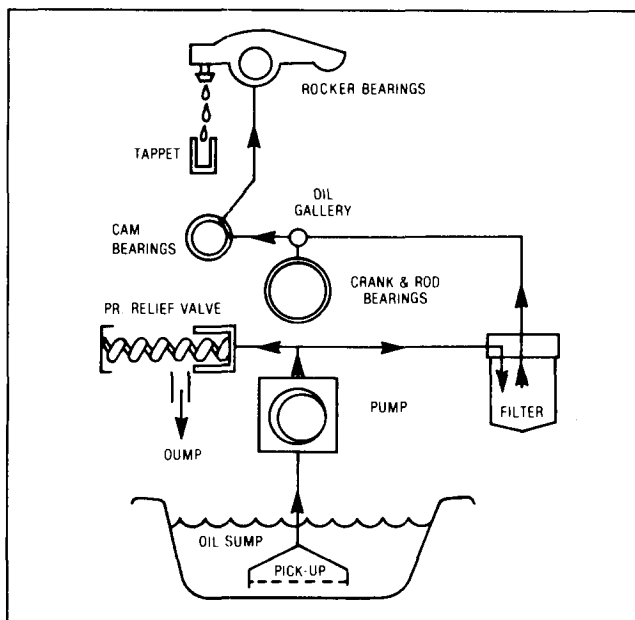

Full-Flow Filter System

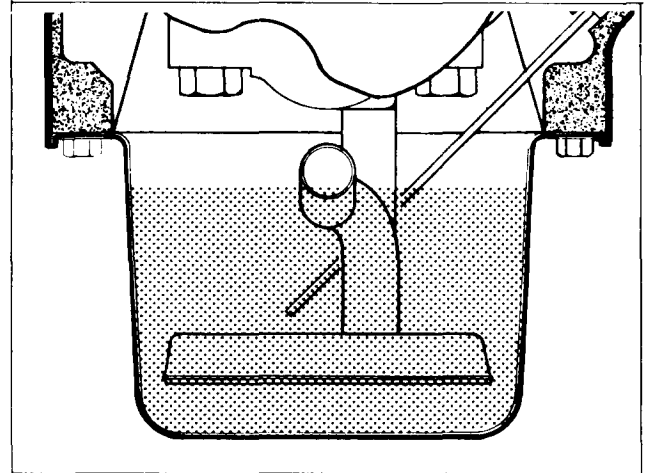

Oil Pump

### OIL CHANGE FREQUENCY

Engine oil does not "wear out". However, the lubricating oil in internal-combustion engines becomes contaminated from the by-products of combustion: dirt, water, unburned fuel entering the crankcase, and the detergents holding the carbon particles in suspension in the crankcase.

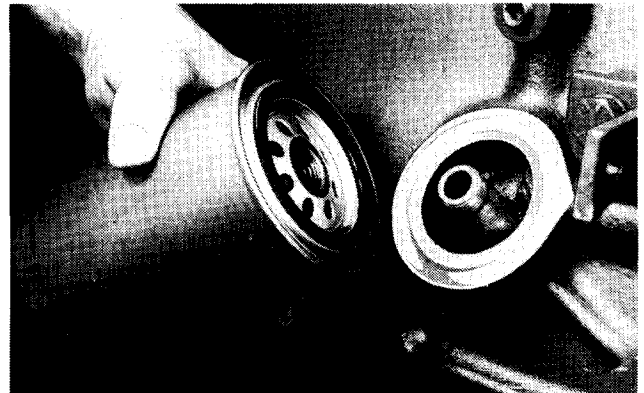

Oil Filter

The schedule for changing oil is directly dependent upon the operational environment: an extremely clean operation could go 100 hours while a dirty operation (foundry or cement factory) could be 50 hours or less (see Suggested Oil and Filter Change Intervals, page 14).

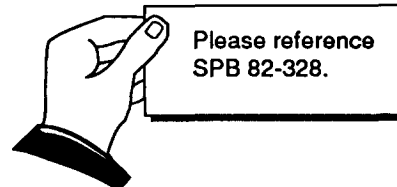



## LUBRICATION RECOMMENDATIONS

Motor oils used for internal-combustion engine lubrication perform many useful functions including: Dissipating heat, sealing piston rings, preventing metal-to-metal contact wear and reducing power loss through friction.

The lubricating oil recommendation is based upon engine design, type of service, and the atmospheric temperature prevailing. High quality oils are required to assure maximum performance, long engine life, and minimum cost of operation.

Continental industrial engines operate in a wide range of service conditions and seasonal temperatures, so our recommendations are given for various types of service and ambient temperatures.

## LUBRICANT DESIGNATIONS

We recommend using oil described below for all Continental industrial applications (Gasoline - LPG - Natural Gas).

	<b>API, SAE</b>
<b>Fuel Type</b>	<b>ASTM Classification</b>
Gasoline	SE, SF, SE/CD, SF/CD
LPG/Natural Gas	SE, SF, SE/CD, SF/CD

Service typical of industrial gasoline engines operating under engine manufacturer's warranties. Oils designed for this service provide more protection against oil oxidation, high temperature engine deposits, rust and corrosion in gasoline engines than oils which are satisfactory for API Engine Service Classifications SD or SC.

## S.A.E. OIL BODY GRADES

The oil grades available from the lightest (SAE 5W) to the heaviest (SAE 50) are:

5W	10W	15W	20W	20	30	40	50
5W - 20							
			10W - 30				
		15W - 50					

Multi-Grade Oils such as SAE 5W-20 and SAE 15W-50 have the starting grade characteristics of the lighter oil and after warm up have the running characteristics of the heavier grade.

The following SAE grades are general recommendations for Continental Industrial engines during changing seasonal atmospheric temperatures:

AVERAGE AMBIENT TEMPERATURE AT WHICH ENGINE STARTING IS REQUIRED:							
°C	-30	-18	17	5	16	27	38 +
°F	-20	0	20	40	60	80	100 +
						SAE 40	
				SAE 30			
			SAE 20W/20				
		SAE 10W					
		SAE 20W - 50					
		SAE 20W - 40					
		SAE 15W - 50					
		SAE 15W - 40					
		SAE 10W - 40					
		SAE 10W - 30					
		SAE 5W - 20					

For engines in continuous duty oil viscosity should be based on sump oil temperature.

Sump Oil Temperature	SAE Grade
210 - 250 °F (99 - 121 °C)	40
	30
160 - 210 °F (71 - 99 °C)	30
	10W - 30, 10W - 40
	20W - 40, 15W - 40
	20W - 50, 15W - 50
130 - 160 °F (55 - 71 °C)	20
	10W - 30, 10W - 40

The Multi-Grade oil used should cover the single grade recommendation for the atmospheric temperature involved, e.g. SAE 10W-30 covers SAE-10W, SAE-20W, SAE 20 and SAE 30.

## SUGGESTED OIL AND OIL FILTER CHANGE INTERVALS

Continuous Duty at Continuous Duty Rating		Light Duty Operation (25% Max. Continuous Rating) and Standby
CLEAN ENVIRONMENT	DIRTY ENVIRONMENT	
Gasoline 100 Hours Max.	50 Hours	100 Hours Max.
LPG/Natural Gas 100 Hours Max.	50 Hours	200 Hours Max.

**NOTE:** 1. Lube oil and filter must always be changed after the first 50 hours of operation of a new or rebuilt engine.

2. Environmental, installation, fuel system and general engine conditions can all influence lubricant performance. Lube oil analysis programs are recommended in all applications for optimum engine performance and life.

Standard Continental supplied starters and alternators have sealed bearings requiring no lubrication. Check your specification for accessories which may require periodic lubrication.

# Section 4 - Cooling System

The function of the cooling system is to prevent the temperatures in the combustion chamber, which may reach as high as 2200 °C (4000 °F.) from damaging the engine and at the same time keep the operating temperatures within safe limits.

Maintaining the cooling system efficiency is important, as engine temperatures must be brought up to and maintained within satisfactory range for efficient operation; however, this system must be kept from overheating, in order to prevent damage to valves, pistons and bearings.

## COOLING SYSTEM

All Continental industrial engines have the cooling water force-circulated by a water pump and use a thermostat and by-pass system to control the temperature range.

The coolant from the pump enters the front of the block, passing along and between the cylinder bores and is metered by the head gasket into and across the cylinder head to cool the valve seats and guides. The heated coolant then enters the manifold and passes thru the thermostat to the radiator.

Upon leaving the cylinder head, the water enters the thermostat housing, in which is mounted the positive shut-off thermostat, which controls the opening to the radiator or heat exchanger. Upon being discharged from the thermostat housing, the water enters the radiator or heat exchanger, depending upon the application, where it is cooled before re-entry into the engine.

Continental industrial engines operate most efficiently with water temperatures of 81°-93°C (180°-200°F) and a thermostat and by-pass system is used to control these temperatures.

The thermostat valve remains closed and only allows the water to recirculate within the engine itself until normal operating temperatures are reached. This provides for both rapid and even temperature increase of all engine parts during the warm-up period. When desired temperature is reached, the thermostat valve opens allowing all the water to circulate through both the engine and radiator, while shutting off the by-pass system.

**IMPORTANT:** Present thermostats begin to open at 81 °C (180 °F) and are fully open at 94 °C (202 °F.). Operation of engines in this temperature range is not harmful. However, temperature gauges are not always accurate and may sometimes indicate higher than actual temperature. This can lead operators to believe engines are overheating when they are actually operating normally.

Overheating is always accompanied by loss of coolant water. In case of doubt, this should be checked.

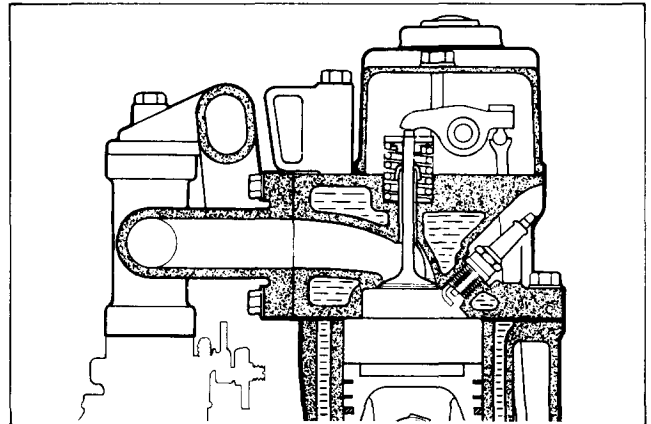

Sectional View Showing Water Passages in Head and Block

## EXPANSION OF WATER

Water has always been the most commonly used coolant for internal combustion engines because it has excellent heat transfer ability and is readily obtained everywhere. Like all liquids it expands when heated, the rate of expansion being 1/32 liter per liter (1/4 pint per gallon) when the temperature is raised from 4° to 81 °C (40° to 180 °F.).

For example: If a 4 gallon cooling system is filled completely full of water at 4°C (40°F), 1 pint will be lost through the radiator overflow pipe by the time the water temperature reaches 81°C (180°F).

## WATER FILTERS

In some areas, the chemical content of the water is such that even the best of rust inhibitors will not protect the cooling system from the formation of rust and scale.

There are instances where this corrosive element has eaten holes through cast iron parts such as water pump impellers and bodies. This condi-

tion is caused by electrolysis taking place in the parts involved.

Where these conditions exist, water filters should be incorporated in the assembly to remove these troublesome elements and offset the electrolytic action.

### EFFECT OF ALTITUDE ON COOLING

Water boils at 100°C (212°F.) under atmospheric pressure at sea level. This pressure becomes less at higher altitudes and the reduced pressure causes water and other liquids to boil at a lower temperature.

### ANTI-FREEZES

Water freezes at 0°C (32°F.), forms solid ice and expands about 9% in volume — which causes tremendous pressure and serious damage when allowed to freeze inside the cooling system.

When operating temperatures are below 0°C (32°F.) an anti-freeze liquid must be added which will lower the freezing point a safe margin below the anticipated temperature of outside air.

ANTI-FREEZE	OPERATING TEMPERATURE RANGE		
	0° to -12°C (32° to 10°F.)	-12°C to -23°C (+ 10° to -10°F.)	-23°C to -34°C (-10° to -30°F.)
ETHYLENE GLYCOL (permanent type) — When there are no leaks add water only to make up for evaporation.	Ratio Ethylene Glycol to water		
	1 to 4	2 to 5	1 to 1

### CORROSION INHIBITORS

## WARNING

Corrosion inhibitor can cause damage to the eyes or skin. If contact is made, immediately wash skin with water. For the eyes, immediately flush the eyes with water for several minutes. In either event, seek prompt medical attention.

Read and observe safety warnings on pages 1 and 2.

Water forms rust due to its natural tendency to combine chemically with iron and air in the system. Rust inhibitors for water are inexpensive, simple to use and make cleaning and flushing necessary only after long periods of operation.

Please reference SPB 90-409.

### RADIATOR

The radiator or heat exchanger consists of a series of metal tubes through which the coolant is circulated. In standard radiator design fins are connected to the metal tubes to give an extended surface through which heat can be dissipated. It is important that these tubes be kept clean on the inside and the fins free of dirt on the outside so the maximum heat transfer can take place in the radiator.

## WARNING

If the coolant is hot or if the engine has been running, loosen the pressure cap to the first stop and let the pressure out of the cooling system before removing the radiator cap.

Read and observe safety warnings on pages 1 and 2.

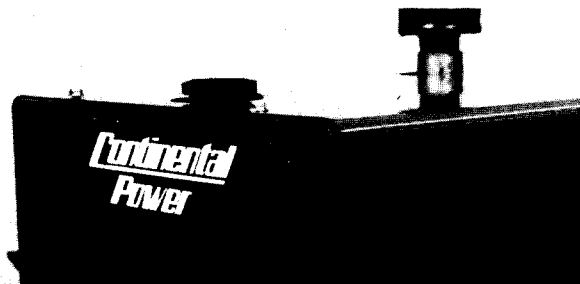

Radiator Coolant Inlet

Blowing out between the fins of the radiator, using compressed air, in a direction opposite to that of the fan circulated air, will serve to keep the cooling surfaces of the core free of dirt and other particles. Operating conditions will determine the frequency of this service.

Every 500 hours of operation the radiator and cooling system should be well cleaned and flushed with clean water.

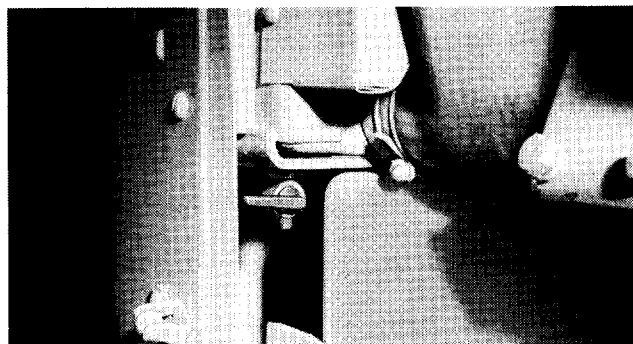

Radiator Drain

Wherever possible, only soft clean water should be used in the cooling system. Hard water will cause scale to form in the radiator and the engine water jackets and cause poor heat transfer. Where the use of hard water cannot be avoided an approved water softener can be used.

### CLEANING COOLING SYSTEM

Deposits of sludge, scale and rust on the cooling surfaces prevent normal heat transfer from the metal surfaces to the water and in time render the cooling system ineffective to properly maintain normal operating temperatures. The appearance of rust in the radiator or coolant is a warning that the corrosion inhibitor has lost its effectiveness and should be cleaned before adding fresh coolant.

Dependable cleaning compounds should be used. Follow the procedure recommended by the supplier. This is of prime importance because different cleaners vary in concentration and chemical compositions. After cleaning and flushing, the system should be filled with an approved anti-freeze compound containing a rust and corrosion inhibitor or water with a corrosion inhibitor.

## REVERSE FLOW FLUSHING

Whenever a cooling system is badly rustclogged as indicated by overflow loss or abnormally high operating temperatures, corrective cleaning by reverse flow flushing will most effectively remove the heavy deposits of sludge, rust and scale. The reverse flow flushing should be performed immediately after draining the cleaning solution. It is advisable to flush the radiator first, allowing the engine to cool as much as possible.

### Reverse flush the radiator, as follows:

1. Disconnect the hoses at the engine.
2. Put radiator cap on tight.
3. Clamp the flushing gun in the lower hose with a hose clamp.
4. Turn on the water and let it fill the radiator.

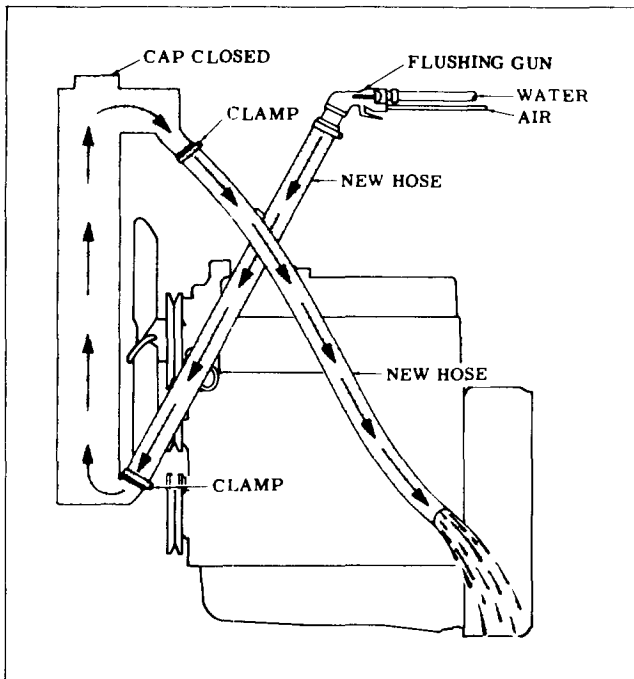

Reverse Flushing Radiator

5. Apply air pressure gradually, to avoid radiator damage.
6. Shut off the air, again fill the radiator with water and apply air pressure — repeat until the flushing stream runs out clear.
7. Clean and inspect radiator cap.

### To Reverse flush the engine water Jacket

1. Remove the thermostat.
2. Clamp the flushing gun in the upper hose.
3. Partly close the water pump opening to fill the engine jacket with water before applying the air.
4. Follow the same procedure outlined above for the radiator by alternately filling the water jacket with water and blowing it out with air 5.5 Bar (80 PSI) until the flushing stream is clear.

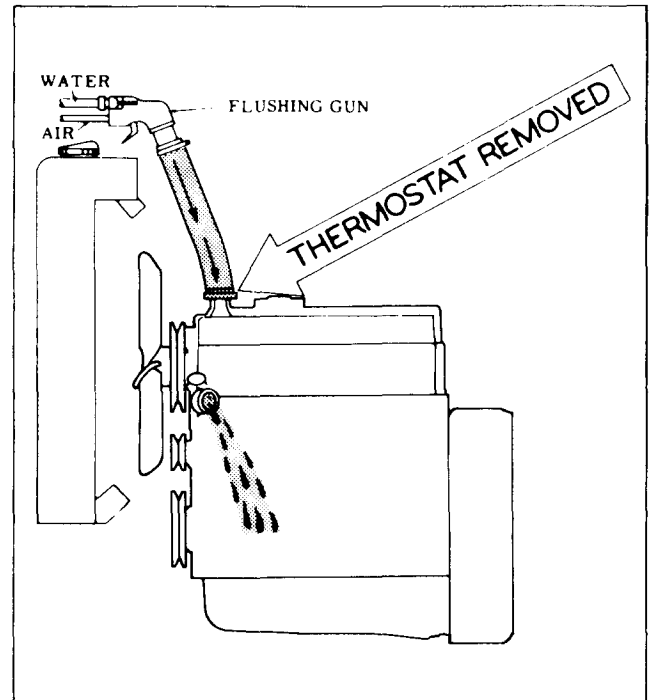

Reverse Flushing Engine

## TESTING THERMOSTAT

Remove the water outlet elbow. Before testing, clean and examine the thermostat. If the valve can be pulled or pushed off its seat with only a slight effort when cold or it does not seat properly, the unit is defective and should be replaced.

The thermostatic operation can be checked in the following method:

1. Hang thermostat by its frame in a container of water so that it does not touch the bottom.
2. Heat the water slowly and check temperature with a thermometer.
3. If the valve does not start to open at temperatures of 81° - 93°C (180° - 200°F.) or if it opens well before the 81°C (180°F.) point is reached, the thermostat should be replaced.

When replacing the thermostat in the water header be sure the counterbore is clean.

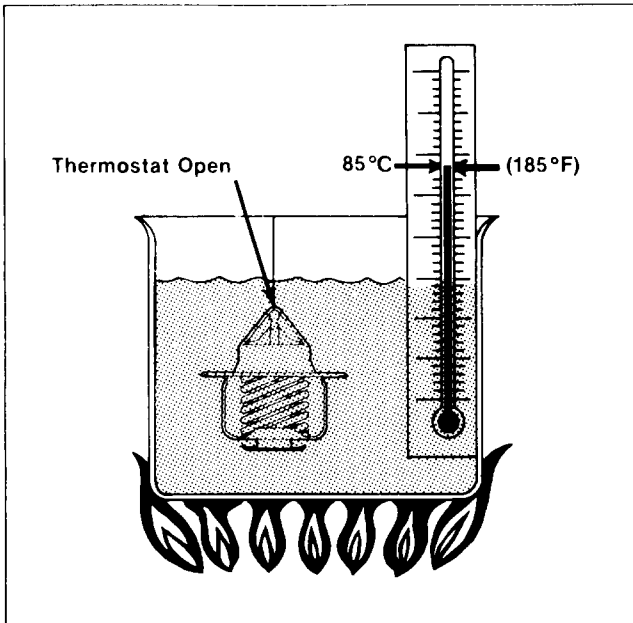

Checking Thermostat

When installing a new thermostat in the water header make sure that the temperature sensing unit goes in first or faces toward the cylinder head.

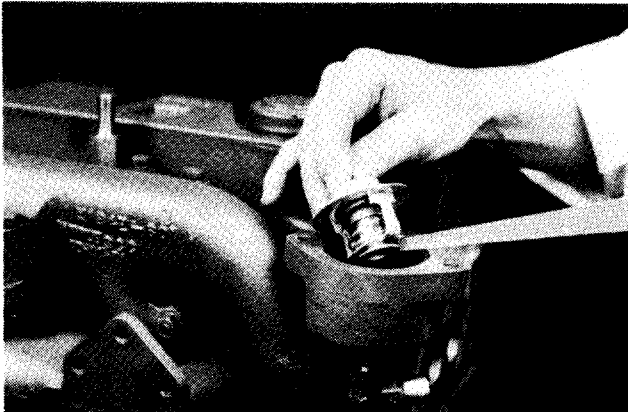

Installing Thermostat

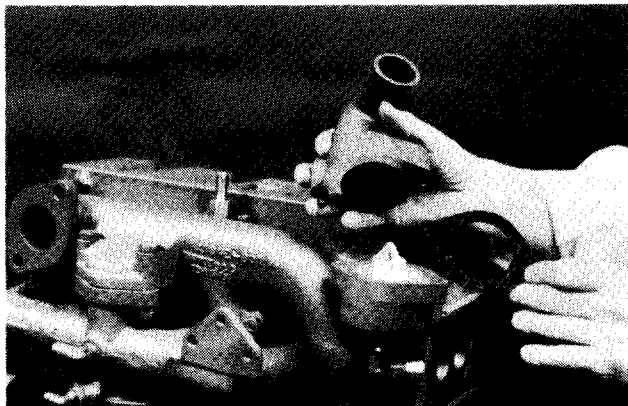

Installing New Gasket

Assemble new water outlet elbow mounting gasket. Thermostat flange must seat in counter-bore with gasket sealing contact between it and the outlet elbow.

## RADIATOR PRESSURE CAP

### **WARNING**

If the coolant is hot or if the engine has been running, loosen the pressure cap to the first stop and let the pressure out of the cooling system before removing the radiator cap.

Read and observe safety warnings on pages 1 and 2.

Many operations use a pressure cap on the radiator to prevent overflow loss of water during normal operation. This spring loaded valve in the cap closes the outlet to the overflow pipe of the radiator and thus seals the system, so that pressure developing within the system raises the boiling point of the coolant and allows higher temperatures without overflow loss from boiling. Most pressure valves open at 0.3 or 1.0 Bar (4 1/2 or 15 PSI), allowing steam and water to pass out the overflow pipe, however, the boiling point of the coolant at this pressure is 107 °C (224 °F) or 120 °C (248 °F) at sea level. When a pressure cap is used an air tight cooling system is necessary with particular attention to tight connections and a radiator designed to withstand the extra pressure.

## PRESSURE CAP

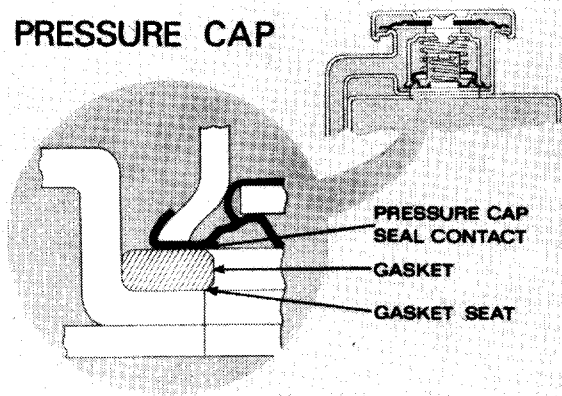

## FAN BELT TENSION

When tightening fan belts, loosen the alternator adjusting bolts and pull out on the alternator by hand until the belt is just snug. Under no circumstances should a pry bar be used on the alternator to obtain fan belt tension or damage to the bearings will result.

When adjusted correctly the fan belt deflection on the long side should not exceed 13mm (1/2").

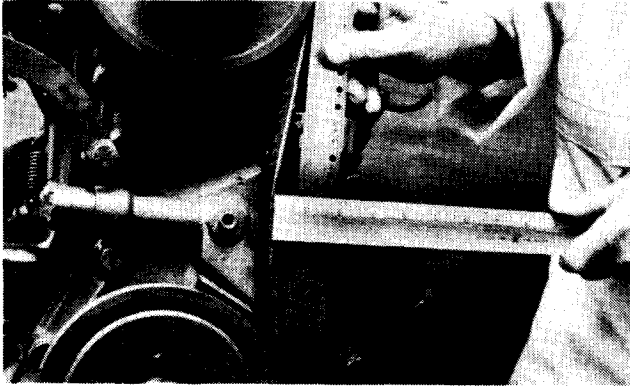

Adjusting Fan Belt Tension

## CYLINDER BLOCK WATER DRAINS

When the cooling system is to be completely drained, there is a drain plug on the right hand side of the cylinder block which drains all cooling water which might be trapped in the base of the block.

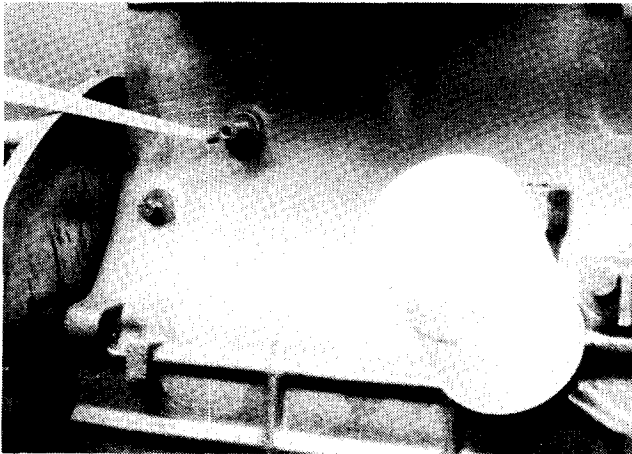

**CAUTION: OVERHEATED ENGINE** Never pour cold water or cold anti-freeze into the radiator of an overheated engine. Allow the engine to cool and avoid the danger of cracking the cylinder head or block. Keep engine running while adding water.

## WATER PUMP

The water pump is located on the front of the cylinder block and is driven by the fan belt from the crankshaft pulley. The inlet of the water pump is connected to the lower radiator connection and the outlet flow from the pump is through integral passages cast in the block.

No lubrication of the pump is required as the bearings are of the permanently sealed type and are packed with special lubrication for the life of the bearing.

The water pump requires no attention other than bearing replacement when it shows excessive looseness or if a water leak develops which shows a damaged or badly worn seal that needs replacement.

## **WARNING**

Corrosion inhibitor can cause damage to the eyes or skin. If contact is made, immediately wash skin with water. For the eyes, immediately flush the eyes with water for several minutes. In either event, seek prompt medical attention.

Read and observe safety warnings on pages 1 and 2.

## REMOVING WATER PUMP

The water pump assembly can be removed from the engine as a unit for service or repair in the following manner:

1. Drain coolant.
2. Remove fan by taking out four cap screws.
3. Loosen alternator so that fan belt can be slacked off enough to slide over pulley.
4. Remove fasteners holding the pump body to the front of the block and remove the pump assembly.

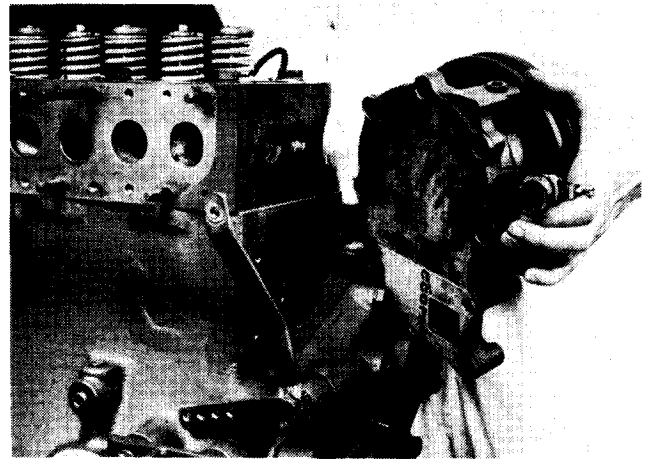

Removing Water Pump

## DISASSEMBLY OF WATER PUMP

When replacement of any internal parts becomes necessary, disassembly must be in the following sequence in order to prevent damage to the pump.

1. Use puller to remove the fan hub (11) from shaft.
2. Remove countersunk screws (1) holding cover (2) removing cover and gasket (3).
3. Use puller to remove impeller (4) taking precautions to prevent damage to the casting.
4. Remove seal (5) and gasket (6).

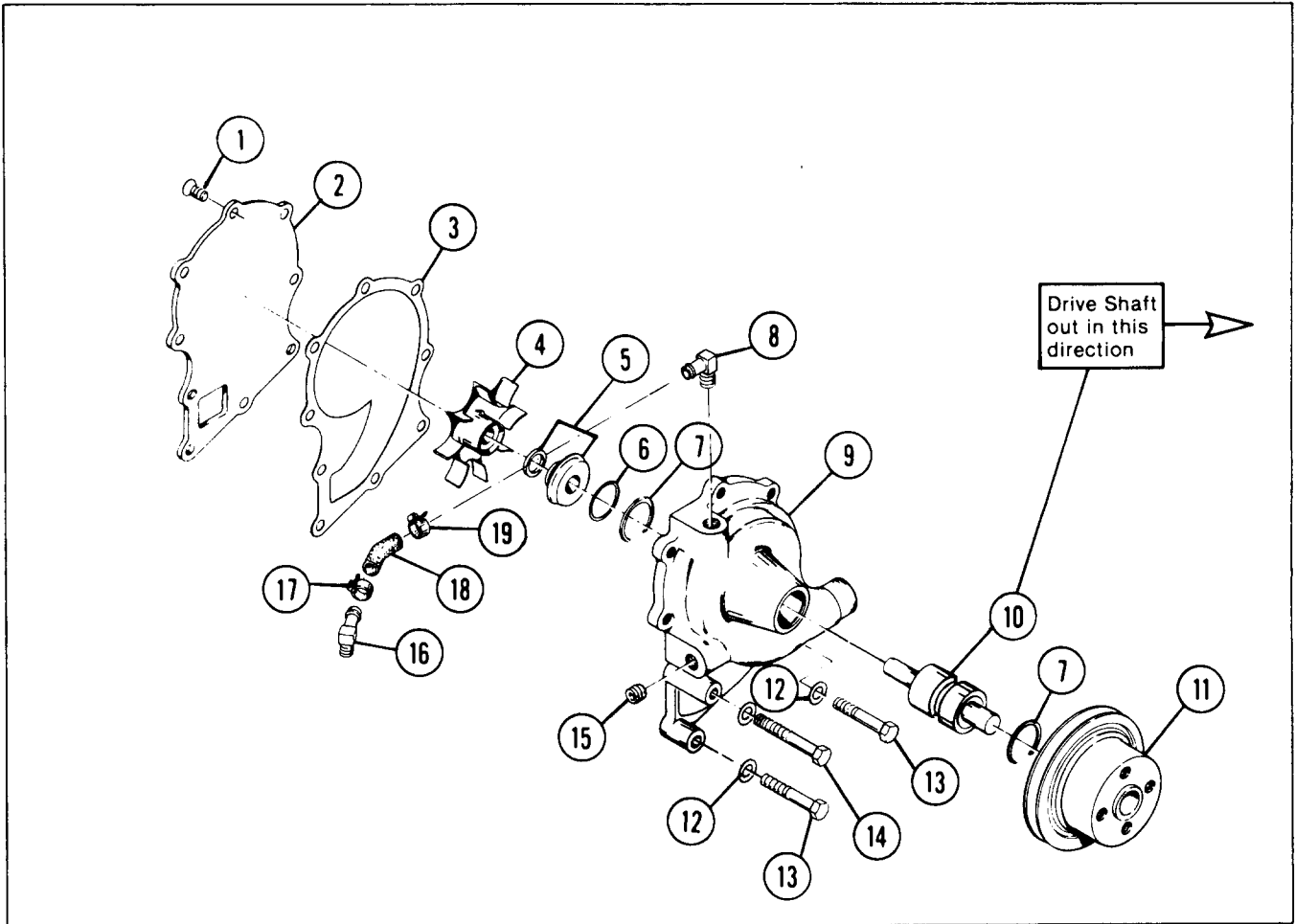

Disassembling Water Pump

5. Remove lock rings (7) holding bearing and shaft assembly in body after which shaft (10) can be forced out through the front with an arbor press or lead hammer. **DO NOT ATTEMPT TO DRIVE WATER PUMP SHAFT (10) OUT THROUGH REAR OF HOUSING.** To do so will damage the housing beyond repair.

**REASSEMBLY AND INSTALLATION**

1. Reassemble pump, replacing worn or failed parts.

Seal contact surfaces must be smooth and flat. The bushing should be replaced if scored or cut.

A light film of lubricant applied to the face of the seal will facilitate seating and sealing.

2. Use thick soapsuds on both the seal and shaft when assembling in order to prevent damage to the seal.

3. The fan hub must be installed prior to replacing rear plate. The shaft must be supported during this operation to prevent damage to the seal and bushing.

4. Mount pump assembly on block using a new housing gasket.

5. Install fan belt and adjust belt tension to have 13mm (1/2") deflection on long side.

Pull out the alternator by hand, as bearing damage will result with a pry bar.

6. Refill cooling system.

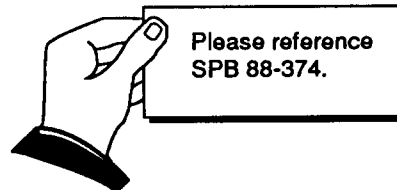

# Section 5 - Fuel Systems

The basic purpose of the fuel system is to store, convey, mix fuel with air, then vaporize and introduce the mixture into the engine.

Fuel is stored in the tank; it is filtered and flows through the fuel supply line to the carburetor — either by gravity or under pressure of a fuel pump. The carburetor mixes the fuel with proper proportions of air and at the same time breaks it into very fine spray particles. This atomized spray changes to vapor, by absorbing heat as it travels through the intake manifold to the combustion chamber. Fuel must be vaporized since it will not burn as a liquid.

## GRAVITY FUEL SYSTEM

This is the most simple fuel system and is generally used on power units as it eliminates the need for a fuel pump — it only requires that the tank be located higher than the carburetor.

All power units with a fuel tank should have a combination shut-off valve and an efficient metal edge type filter. This filter prevents all foreign particles and water from entering the carburetor.

With reasonable care in filling the tank with clean fuel, this filter will require only seasonal cleaning of both the filter and tank.

**CAUTION:** It is recommended that the fuel shut-off valve be kept in the closed position except when unit is in operation.

## MECHANICAL FUEL PUMP

**NOTE:** Not available on the 2 cylinder engine.

The Mechanical Fuel Pump is generally used when the fuel supply is below the level of the carburetor.

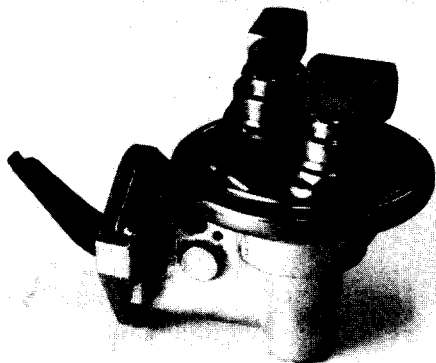

Fuel Pump

This mechanical fuel pump mounts on the cylinder block pad and is driven by an eccentric on the engine camshaft contacting the fuel pump rocker arm.

Constant fuel pressure is maintained by an air dome and a pulsating diaphragm operated and controlled by linkage which adjusts itself to pressure demands.

**Fuel Pump Tests** — The fuel pressure may be measured by installing a pressure gauge between the fuel pump and carburetor.

The fuel pump size and static pressures @ 1800 R.P.M. for the overhead valve engines are:

ENGINE MODEL	DIAPHRAGM DIAMETER	FUEL PRESSURE	MAX. LIFT
TM	82.6mm (3 1/4")	77-116mm Hg (1 1/2 - 2 1/4 PSI)	3m (10')

## ⚠ WARNING

Smoking or open flame should be avoided any time the fuel system is being repaired or serviced. The area should be properly ventilated. Improper handling of fuel could result in an explosion or fire causing bodily injury to yourself or others.

Read and observe safety warnings on pages 1 and 2.

When pressures are below the range, the pump should be disassembled and reconditioned with the special overhaul kits available.

**Maintenance** — Fuel pump trouble is of only two kinds — either the pump is supplying too little gas or, in rare cases, too much.

If the pump is supplying too little gas, the engine either will not run or it will cough and falter. If too much gas — it will not idle smoothly or you will see gasoline dripping from the carburetor.

**If the engine is getting too little gas** — the trouble may be in the pump, fuel line, plugged filter, or the gas tank. First, be sure there is gas in the tank, then disconnect the pump to carburetor line at the pump or carburetor, and turn the engine over a few times with the ignition off. If gas spurts from the pump or open end of the line — the pump, gas line and tank are OK.



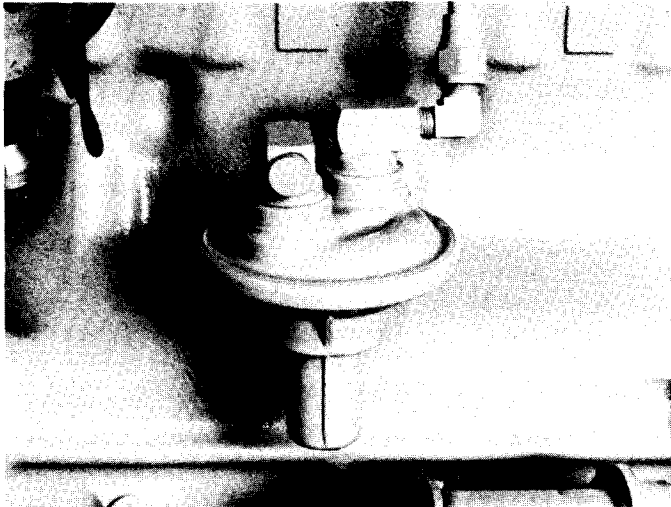

Checking Fuel Flow

**If there is little or no Flow** — check the following:

1. Look for leaky diaphragm cover gasket or line connections — tighten them.
2. Look for clogged fuel line — Blow out with compressed air.
3. Make sure that all pump cover screws and external plugs are tight.
4. Inspect flexible fuel line for deterioration, leaks, chafing, kinks or cracks. If none of these items restore proper flow — remove the pump for replacement or overhaul.

**If getting too much gas** — an oversupply of gasoline is generally caused by trouble other than the fuel pump — so first check the following:

1. Excessive use of hand choke.
2. Loosely connected fuel line, or loose carburetor assembly screws.
3. Punctured carburetor float.
4. Defective carburetor needle valve.
5. Improper carburetor adjustment.

If none of these items corrects flooding, remove the fuel pump for replacement or overhaul.

## ELECTRIC FUEL PUMP

Many Continental industrial engines use electric fuel pumps operated from the storage battery supply. The pump should be mounted close to the fuel tank so as to provide fuel pressure at all points along the fuel line and so eliminate vapor lock.

The electric fuel pump is energized in the ignition circuit — which assures quick filling of carburetor and fuel line to effect easy starting.

When fuel pump trouble is suspected, disconnect the fuel line at the carburetor and turn on the ignition switch. Pump fuel into a small container,

then place your finger on the outlet side of the fuel line. If the pump stops or ticks very infrequently, the pump and fuel line connections are satisfactory. Remove your finger from the outlet side of the fuel line and if ample fuel flows — the pump is satisfactory.

If fuel does not flow and all connections are tight, the pump should be replaced or repaired. Always be sure of a good ground and check for faulty flexible fuel lines and poor electrical connections.

## CARBURETOR

Continental industrial gasoline engines use various models of carburetors.

The carburetor mixes fuel with air and meters the mixture into the engine as the power is demanded. Most carburetors incorporate the following systems to provide the flexibility and sensitive requirements of varying loads and conditions:

1. **Float System** — Controls the level and supply of fuel.
2. **Idle or Low Speed** — Furnishes the proper mixture for the engine idle, light load and slow speeds, until the main metering system functions.
3. **Main Metering System** — Controls the fuel mixture from part throttle operation to wide open throttle.
4. **Power or Economizer Systems (optional)** — Provides a richer mixture for maximum power and high speed operation and a leaner mixture for part throttle operation.
5. **Compensating System** — Provides a mixture which decreases in richness as the air speed increases.
6. **Choke System** — Delivers additional fuel to the manifold for cold engine starting.

## CONTINENTAL CARBURETOR

The Continental CK series carburetor has the following adjustments:

1. **Idle Fuel Adjusting Needle** — should be seated lightly with small screw driver, turning in (clockwise). It is then backed out (counter clockwise) 1¼ turns as a preliminary setting. Fuel Flow is regulated like a water faucet, turn in to shut off, back out to open.

2. **Fixed High Speed Jet** — is not adjustable. For high altitude it may be exchanged for reduction in size to lean the fuel in compensation for the lighter, thin air. The size must be carefully determined first by testing a smaller jet with .025 - .050mm (.001" to .002") smaller passage depending on the elevation.

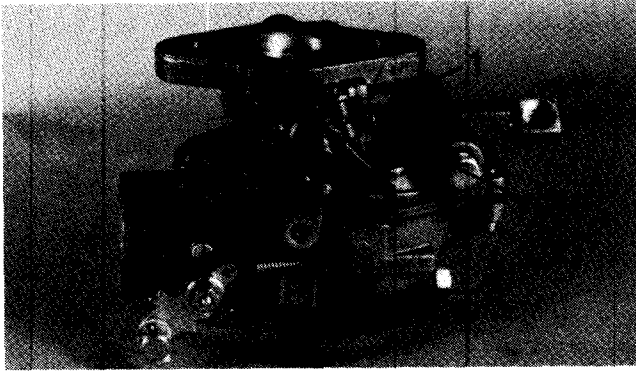

Typical Continental Carburetor

**2.A. Main Jet Adjusting Needle** — available for use with the fixed high speed jet for altitude compensation. Turn (in) for leaner mixture and (out) for richer mixture.

**CAUTION:** Improper adjustment of the main jet could lead to engine damage.

**3. Idle Speed Adjustment Screw** — turn in clockwise until throttle valve is slightly cracked open. Adjustment to recommended idle speed can be made after installation to engine. Turn screw clockwise to increase speed or counter-clockwise to lower the R.P.M.

### ZENITH (FACET) CARBURETOR

The Zenith (Facet) 267 series updraft carburetor has the following adjustments:

**1. Idle Fuel-Air Adjusting Needle** — The idle fuel-air adjusting needle controls the amount of fuel-air mixture discharged into the air stream. Turning the idle adjusting needle (in) results in a leaner mixture. Turning the idle adjusting needle (out) results in a richer mixture.

**2. Fixed High Speed Jet** — is not adjustable. For high altitude it may be exchanged for reduction in size to lean the fuel in compensation for the lighter, thin air. The size must be carefully determined first by testing a smaller jet with .001 to .002 smaller passage depending on the elevation.

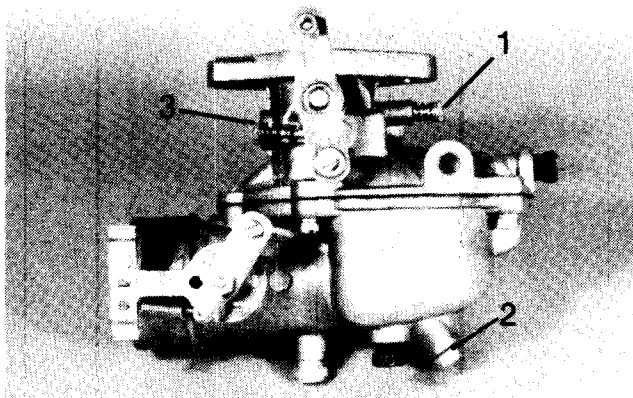

Zenith Carburetor (267 Series)

**2.A. Main Jet Adjusting Needle** — available for use with the fixed high speed jet for altitude compensation. Turn (in) for leaner mixture and (out) for richer mixture.

**CAUTION:** Improper adjustment of the main jet could lead to engine damage.

**3. Idle Speed Adjusting Screw** — turn (in) clockwise until throttle valve is slightly open. Adjustment to recommended idle speed can be made after installation to engine. Turn screw clockwise to increase speed or counter-clockwise to lower the R.P.M.

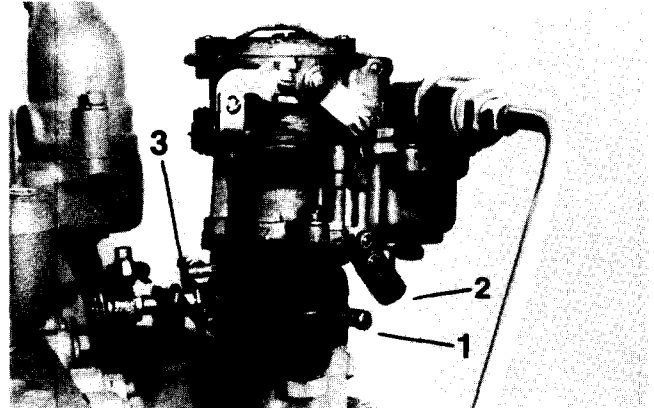

Zenith Carburetor (228 Series)

The Zenith (Facet) 228 Series downdraft carburetor has the following adjustments:

**1. Idle Fuel-Air Adjusting Needle** — The discharge of the idle fuel-air mixture into the air stream is controlled directly by the idle adjusting needle located in the throttle body at the lower idle discharge hole. Turning the idle needle valve in (clockwise) results in a leaner mixture of fuel-air since less of the fuel-air mixture is discharged into the air system through the idle discharge hole.

**2. Fixed High Speed Jet** — is not adjustable. For high altitude it may be exchanged for reduction in size to lean the fuel in compensation for the lighter, thin air. The size must be carefully determined first by testing a smaller jet with .001 to .002 smaller passage depending on the elevation.

**2A. Main Jet Adjusting Needle** — available for use with the fixed high speed jet for altitude compensation. Turn (in) for leaner mixture and (out) for richer mixture.

**CAUTION:** Improper adjustment of the main jet could lead to engine damage.

**3. Idle Speed Adjusting Screw** — turn (in) clockwise until throttle valve is slightly open. Adjustment to recommended idle speed can be

made after installation to engine. Turn screw clockwise to increase speed or counter-clockwise to lower the R.P.M.

## CARBURETOR CHOKES

**Manually Operated Choke** — is operated by a flexible cable control from the instrument panel or rear house panel. While this is the most simple type, it is most important that the operator have the choke valve in wide open position when engine operating temperature is reached.

**Carburetor Service** — In general any change in carburetor action will usually come gradually, therefore, if the carburetor operated satisfactorily when last used, it can reasonably be assumed that some other part of the engine is at fault — which should be corrected before disturbing the carburetor.

Dirt is the main enemy of good carburetion as it fills up the minute air and gasoline passages and accelerates the wear of delicate parts.

Never use a wire to clean out restriction in jets as this will destroy the accurate calibrations of these parts — **always use compressed air**. The jets are made of brass to prevent rust and corrosion and a wire would cut or ream the hole in the jet and ruin it.

Maintaining correct fuel level in the carburetor bowl is important — as the fuel flow through the jets is naturally affected by the amount of fuel in the bowl.

After a carburetor has been in service for some time, the holes in the jet and the float valve and seat become worn from the constant flow of fuel through them and should be overhauled by a competent carburetor service station.

Do not experiment with other size jet or any so called fuel-saving gadgets as your arrangement has been thoroughly tested on a dynamometer program.

## DRAINING FUEL FROM CARBURETOR

### **WARNING**

Smoking or open flame should be avoided any time the fuel system is being repaired or serviced. The area should be properly ventilated. Improper handling of fuel could result in an explosion or fire causing bodily injury to yourself or others.

Read and observe safety warnings on pages 1 and 2.

Gasoline must be drained from carburetors, following tests on engine or equipment, if it is to be stored for a period of 2 weeks or more, to prevent harmful residue, resulting from fuel vaporization.

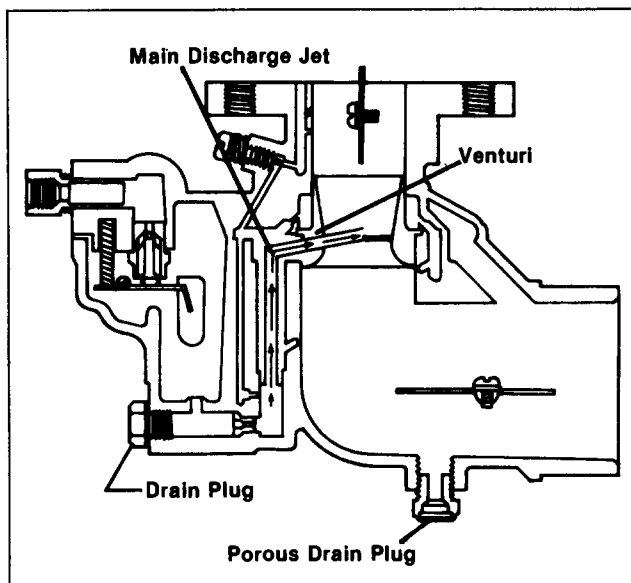

Figure 1

Residue formed in the carburetor is very harmful and will result in malfunction of the engine.

All carburetors have a drain plug in the bottom of the carburetor bowl which should be removed and drained dry, Figure 1.

All engines shipped from the factory have had the fuel drained from carburetor before shipping.

### **WARNING**

Painting of porous carburetor drain plug can cause fire hazard.

Read and observe safety warnings on pages 1 and 2.

**IMPORTANT:** On all gasoline engines with updraft carburetors, it is very important not to paint over the powdered bronze carburetor drain plug shown in Figure 1. This has to remain porous to drain off excess gasoline from over choking. If this plug is sealed, gas can back up into the air cleaner hose and create a fire hazard.

If the carburetor is to be painted, coat this porous plug with a thin coat of grease to prevent any sealing action.

### **WARNING**

**ENGINES USING NATURAL GAS OR LIQUID PETROLEUM GAS (LPG), SEE WARNINGS ON PAGES 1 AND 2.**

Consult handbooks and safety instructions provided by manufacturer of end item in which such engine is used or handbooks and safety instructions of the manufacturer of the natural gas or LPG system **BEFORE** undertaking any work on such system or before any work is begun on the engine or engine sub-systems requiring engine operation.

**CAUTION:** Prior to the use of gasohol fuel, contact the engine manufacturer.

# Section 6 - Governors

## GOVERNORS

The governor is a device which controls engine speed — either keeping it operating at a constant speed or preventing it from exceeding a predetermined speed.

Continental industrial engines use many types of velocity and centrifugal governors -however the majority use centrifugal (Mechanical) governors.

### CHECKING AND ADJUSTING MECHANICAL - GOVERNOR LINKAGE

The following is a step by step procedure to follow in checking and adjusting the governor linkage:

1. With the engine stopped and spring tension about normal, the governor should hold the throttle in the open position. The governor to carburetor control rod should be adjusted in length so the throttle stop lever is 0.4 - 0.8mm (1/64" to 1/32") off the stop pin.
2. Make certain that all linkage is free with spring at operating tension. Disconnect the governor spring and check movement of levers and rods.
3. The hinged lever governor eliminates the need for a spring loaded throttle lever on the carburetor. As the carburetor lever is forced to idle position by the speed control lever, this in turn pivots the top half of the governor arm forward, slowing the engine to idle.

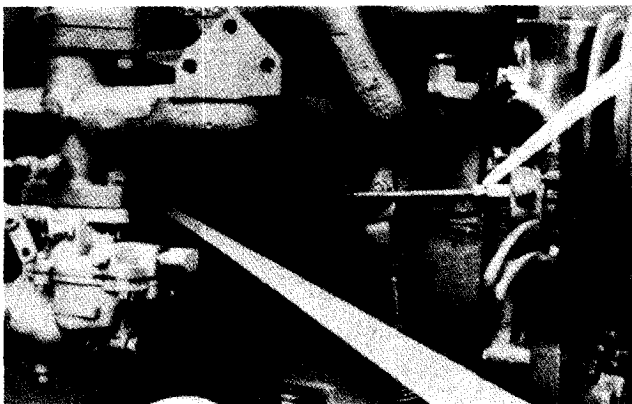

Mechanical Governor Linkage

## CAM GEAR GOVERNOR



Extreme caution must be exercised when making governor adjustments to avoid personal injury due to fan blades, belts and hot manifolds.

Bodily injury or death may result to individuals during operation of an engine within any enclosure not adequately or properly ventilated. Engine operation in any enclosure requires adequate and proper ventilation to avoid asphyxiation or other interruption of normal breathing, to supply sufficient air to cool the engine, provide air to mix with fuel and to carry away heated air from the building.

Read and observe safety warnings on pages 1 and 2.

The Cam Gear Governor — is used on most industrial units requiring normal industrial speed regulation. These governors differ from conventional centrifugal governors mainly in the round steel balls used as the actuating force producer instead of pivoting masses of weight.

When the governor is driven at increasing speeds by the engine, the hardened steel balls, move outward, forcing the conical upper race and lever assembly toward a closed throttle position.

An externally mounted spring imposes tension on the lever assembly toward the open throttle position. As the engine speed increases, the centrifugal force created by the balls will increase until a balanced condition between the governor force and the spring force exists and the governing lever remains stationary — holding a constant engine R.P.M.

Adjustment — The desired engine speed is obtained by increasing or decreasing the governor spring tension.

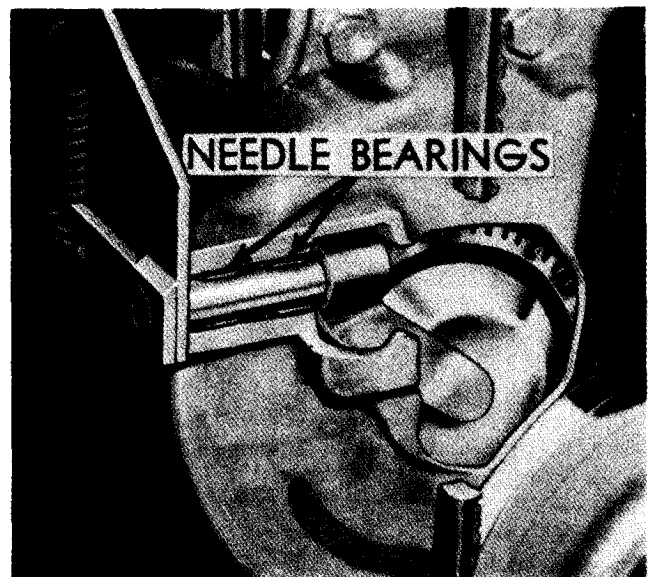

Cam Gear Governor

This built-in cam-gear governor is sealed, dust proof, engine lubricated, is compact and easily adjusted. The control shaft floats on two needle bearings to remove friction for closer and more accurate control through the whole power range. This governor is normally used on all industrial applications.

Control rod movement is determined by accelerator pedal or hand control linkages.

The idle surge adjusting screw, if supplied, should be adjusted "in" just far enough to eliminate any tendency of the engine to surge.

**ADJUSTMENTS:**

**1. Linkage Adjustment** — With the engine stopped and spring tension about normal, the governor should hold the throttle, (butterfly) in the wide open position.

The governor to carburetor control rod should be adjusted in length so that the throttle stop lever is 0.4 - 0.8mm (1/64" - 1/32") off the stop pin. Be sure that the bumper screw, if supplied, is backed out so as not to interfere.

Make certain that all linkage at governor and carburetor operate free — without any binding.

**2. Speed Adjustment** — To increase speed increase spring tension by use of the adjusting screw. To decrease speed decrease spring tension by use of the adjusting screw.

**3. Idle Surge Adjustment** (When Surge Screw is supplied) Turn governor idle surge adjusting screw "IN", or to the right until corrected.

**CAUTION:** Do not turn bumper screw in far enough to reduce the maximum governed speed for full throttle.

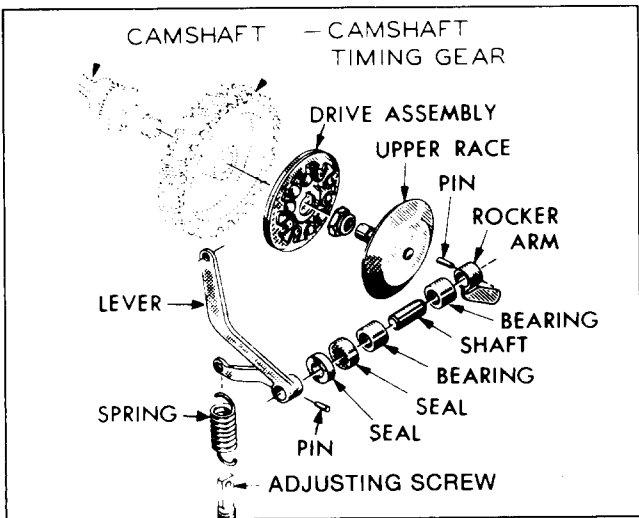

Exploded View of Cam Gear Governor

**4. Continued surging** — may indicate an excessive looseness or binding or governor linkage and sometimes too lean a fuel mixture.

**TM GOVERNOR LINKAGE**

Cam Gear Governor

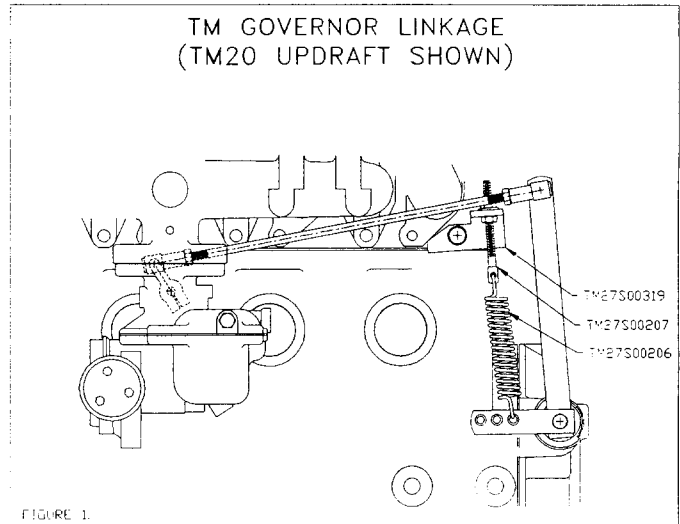

FIGURE 1

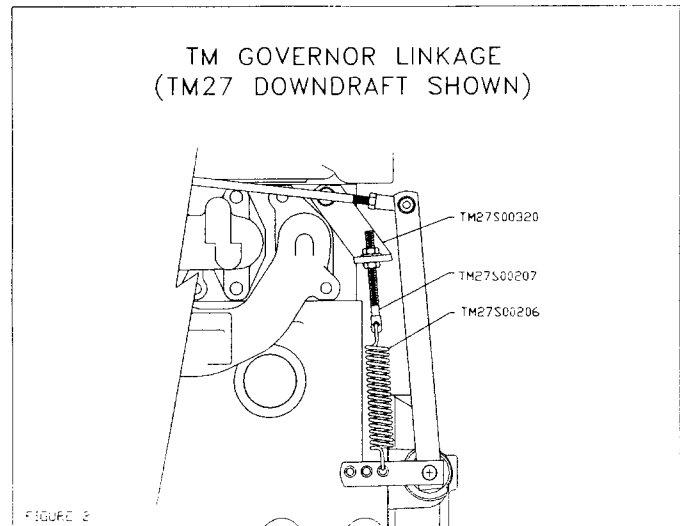

FIGURE 2

**CONSTANT SPEED GOVERNOR**

**⚠ WARNING**

Extreme caution must be exercised when making governor adjustments to avoid personal injury due to fan blades, belts and hot manifolds.

Bodily injury or death may result to individuals during operation of an engine within any enclosure not adequately or properly ventilated. Engine operation in any enclosure requires adequate and proper ventilation to avoid asphyxiation or other interruption of normal breathing, to supply sufficient air to cool the engine, provide air to mix with fuel and to carry away heated air from the building.

Read and observe safety warnings on pages 1 and 2.

**Constant Speed Governor** — is a precision mechanical governor mounted on the left hand side of the engine, driven from the front end gear train. Linkage from the governor thru a cross shaft controls the carburetor.

**Adjustments** — The desired engine speed is obtained by increasing or decreasing the governor spring tension.

1. **Start the engine.** Warm up.
2. **With engine warmed up,** adjust high no load speed approximately 150 R.P.M. higher than the required speed under load, by turning screw (A) in or out, thus either increasing or decreasing tension on the spring.
3. **Apply the desired load,** and readjust screw (A) in order to obtain the required speed under load. Release load and note R.P.M. at which engine settles out.

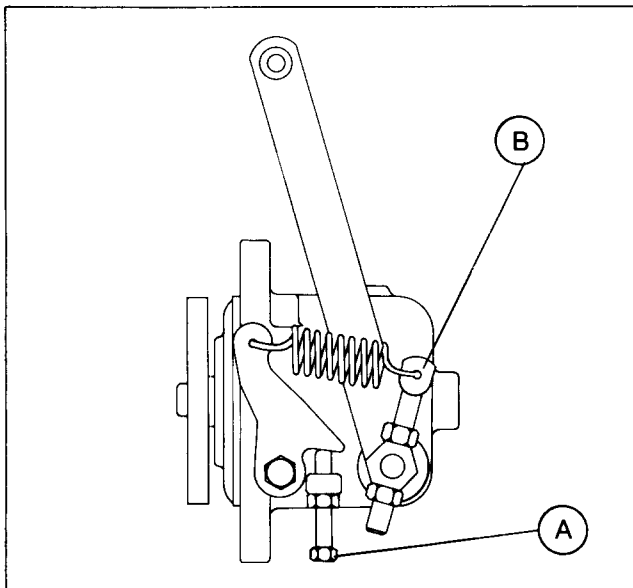

Constant Speed Governor

Again apply load, and observe the drop in R.P.M. before governor opens throttle to compensate.

4. **The range of governor's action** is indicated by the differential between R.P.M. **under load** and that **under no load**.

**This can be varied and the sensitivity of governor changed by changing the length of screw (B).**

5. **To broaden the range of the governor** and produce a more stable action, lengthen screw (B) and compensate for this change by turning screw (A) in to restore speed.
6. **To narrow the range** and increase the sensitivity of the governor, reverse procedure outlined in 5. (Changing the length of screw (B) has the same effect as using a stronger or weaker spring.)
7. **With the governor adjusted for desired performance,** release the load and allow engine to run at governed speed, no load. If a surge is noted, lengthen screw (B) at spring anchor and readjust screw (A) to obtain desired no load R.P.M.

8. **When governor adjustment is completed,** make sure that all lock nuts are tight, in order to maintain the adjustment.

## VARIABLE SPEED GOVERNOR

### **WARNING**

Extreme caution must be exercised when making governor adjustments to avoid personal injury due to fan blades, belts and hot manifolds.

Bodily injury or death may result to individuals during operation of an engine within any enclosure not adequately or properly ventilated. Engine operation in any enclosure requires adequate and proper ventilation to avoid asphyxiation or other interruption of normal breathing, to supply sufficient air to cool the engine, provide air to mix with fuel and to carry away heated air from the building.

Read and observe safety warnings on pages 1 and 2.

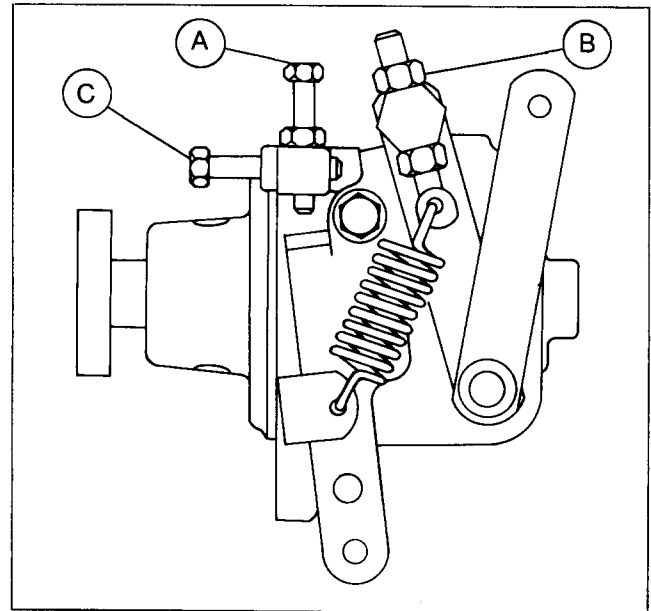

Variable Speed Governor

1. **Start Engine and Idle** until warmed to operating temperature.
2. **Set Specified High Idle No-Load Speed** by moving throttle to required position and adjusting high speed screw (A).
3. **Check Regulation** by Applying and removing engine load.
  - (1) **If regulation is too broad** increase spring tension with sensitivity screw (B) and readjust high speed screw (A) throttle stop to obtain high idle speed.
  - (2) **If regulation is too narrow** decrease spring tension with sensitivity screw (B) and readjust high speed screw (A) throttle stop to obtain desired high idle speed.
  - (3) **If governor surges under load** decrease spring tension with sensitivity screw (B) and readjust throttle lever position to desired high idle speed.

- (4) **Stop Screw (C).** Set for low R.P.M. or idle stop.

**Repeat above steps as required** until desired performance is obtained. When adjustment is complete, lock all lock nuts to maintain settings.

## HINGED LEVER GOVERNOR

### **WARNING**

Extreme caution must be exercised when making governor adjustments to avoid personal injury due to fan blades, belts and hot manifolds.

Bodily injury or death may result to individuals during operation of an engine within any enclosure not adequately or properly ventilated. Engine operation in any enclosure requires adequate and proper ventilation to avoid asphyxiation or other interruption of normal breathing, to supply sufficient air to cool the engine, provide air to mix with fuel and to carry away heated air from the building.

Read and observe safety warnings on pages 1 and 2.

The hinged lever governors are basically the same as other Governors, except the governor arm is in two parts. Pivoted on a pivot bolt, it is spring loaded to hold the arm in a straight position except when low idle is desired.

When carburetor lever is forced to idle position by speed control lever, this in turn pivots top half of governor arm forward.

On some models a small coil spring loaded throttle lever and shaft on the carburetor is used to get idle position.

## VELOCITY GOVERNORS

### **WARNING**

Extreme caution must be exercised when making governor adjustments to avoid personal injury due to fan blades, belts and hot manifolds.

Bodily injury or death may result to individuals during operation of an engine within any enclosure not adequately or properly ventilated. Engine operation in any enclosure requires adequate and proper ventilation to avoid asphyxiation or other interruption of normal breathing, to supply sufficient air to cool the engine, provide air to mix with fuel and to carry away heated air from the building.

Read and observe safety warnings on pages 1 and 2.

**Velocity Governors** — are generally used to prevent engine speed from exceeding a predetermined maximum. The governor is mounted between the carburetor and manifold flanges. In its most simple form, it consists of a main body, which contains a throttle shaft, a throttle valve and a main governor spring. The main governor spring is attached by linkage to the governor shaft and the spring force holds the throttle valve open.

When the engine is started, air flows through the carburetor throat and the governor throat. The velocity of the air creates a pressure above the throttle valve. When this pressure exceeds the force exerted by the spring, the throttle will move toward a closed position. The adjusting screw varies the spring tension.

When this closing action of the valve exactly balances the spring, governing action takes place and maximum speed is fixed at this point.

When load is applied — the engine speed tends to drop — the velocity of the gas through the manifold and the pressure against the governing valve is reduced and the spring opens the valve to feed more gasoline to the engine to handle the increased load demand. Thus an almost constant speed is maintained whether the engine is running with or without load.

The Hoof Velocity Governor is adjusted by removing the seal wire and with screwdriver turn clockwise to increase speed and counter-clockwise to reduce speed.

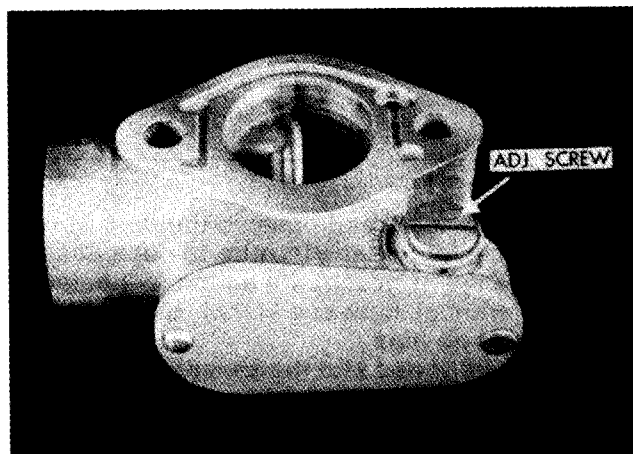

Velocity Governor

# Section 7 - Ignition Systems

Continental industrial spark ignited engines are equipped with an electronic ignition system.

The ignition system has the job of producing and delivering high voltage surges of about 20,000 volts to the correct spark plug, at the correct intervals and with the correct timing for the engine. Each high voltage surge produces a spark at the spark plug gap to which it is delivered, so that the mixture of air and fuel in the cylinder is ignited.

## ELECTRONIC IGNITION SYSTEM

This battery-ignition circuit consists of the battery, ammeter, ignition switch, ignition coil, distributor, spark plugs and low and high tension wiring.

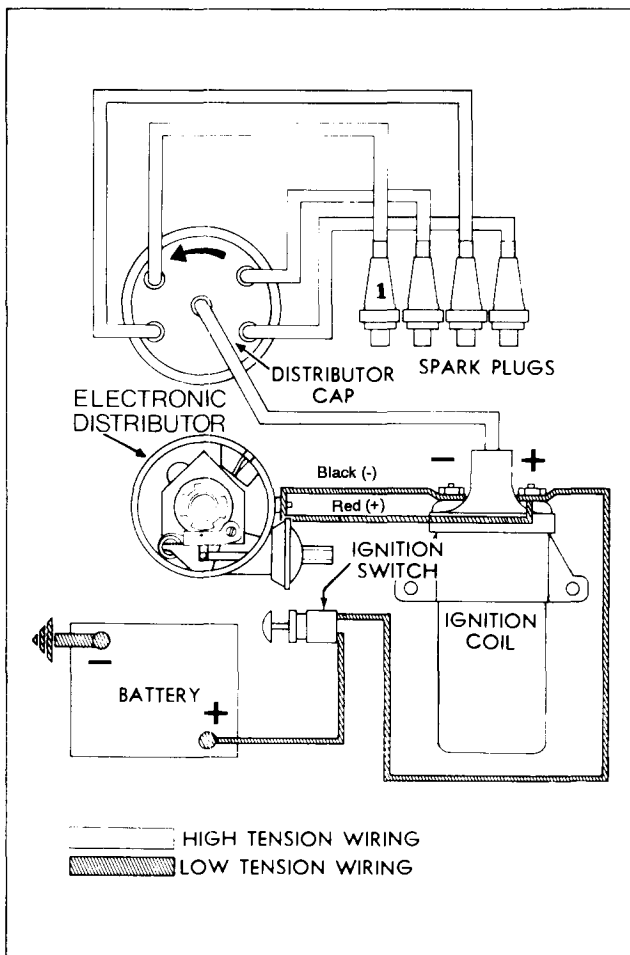

Schematic Drawing of Ignition System (12 Volt)

These parts can be divided into separate circuits consisting of a low tension circuit carrying battery voltage and a high tension spark circuit of about 20,000 volts.

The primary section is the low voltage section and is composed of the battery, the ignition switch, the ignition coil primary winding, distributor electronics and associated wiring.

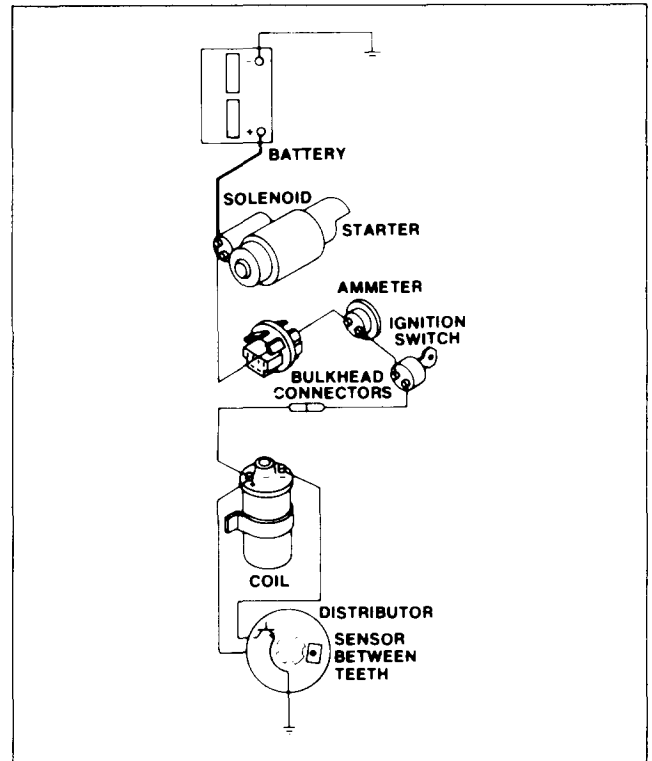

Integral Primary Ignition System

The secondary section is the high voltage section and is composed of the ignition coil secondary winding, the distributor cap, the rotor, the spark plug cables and the spark plugs.

The electronic ignition system maintains a tuned condition longer, since there are no points or condenser. Breaker point erosion and rubbing block wear is eliminated. Wear on the distributor shaft and shaft bearings is greatly reduced. Dwell is permanently controlled by the electronics and total electronic switching offers improved starting. The system is easy to troubleshoot requiring no elaborate test equipment or procedures.

The electronics are fully protected with a moisture resistant material and are designed to resist shock and vibration. Protection against reverse polarity and over voltage is built into the system.

The system will trigger at any speed above zero R.P.M. Each cylinder will fire at the proper time because of close tolerances in the trigger wheel



design. Elimination of points and condensers and their inherent problems such as rubbing block wear, plus the longevity of solid state circuitry offers much less downtime and more economical operation.

This system uses an oscillator as its sensor. Acting as a "Metal Detector", it senses the trigger wheel teeth turning with the distributor shaft. The presence of metal (each tooth) causes a change to occur in the oscillator which in turn commands the control unit transistor switch to turn off.

This off condition causes the primary current to stop flowing and the magnetic field which built up during the on time now will collapse across the secondary coil winding causing the high voltage to fire the spark plug.

The sensor is a coil of very fine wire molded into a plastic housing. This plastic housing is mounted on the movable base plate and is connected directly to the circuit board. The sensor is not replaceable.

The electronic control system is a completely self-contained solid state device which is coated to provide a moisture proof barrier. It is not repairable and if necessary must be replaced as a complete assembly.

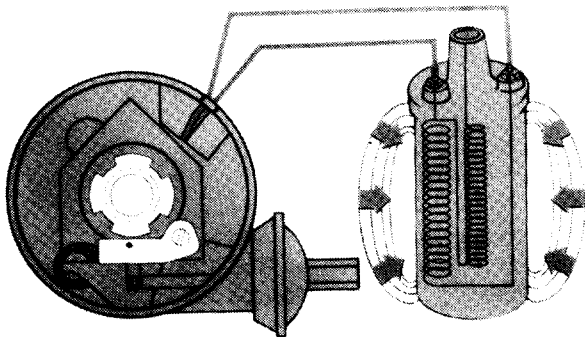

The Integral system houses the electronics inside the distributor. Only two connections are made to the coil.

## IGNITION SYSTEM COMPONENTS

The Battery supplies the voltage for producing a current flow through the ignition circuit.

The Ammeter indicates the amount and direction of current flow.

The Ignition Switch is an "Off" and "On" switch. Current flows only when this switch is closed and returns by the ground through the engine or frame. The resistance of the primary

winding of the ignition coil restricts the primary current flow.

The Ignition Coil consists of two windings, a primary winding and a secondary winding and is a transformer to increase the voltage high enough to jump a spark gap at a spark plug.

The Distributor interrupts the primary winding current in the ignition coil and distributes the high tension current to the correct spark plug at the correct time.

The Spark Plugs provide a spark gap in the combustion chamber. The compressed air and fuel mixture is ignited when the high voltage jumps across this gap.

The Low Tension Primary Wiring conducts battery current through the ignition coil and contacts.

The High Tension Secondary Wiring conducts the high voltage, produced by the ignition coil, to the distributor and from the distributor to the spark plugs.

Operation — A primary current flows from the battery, through the ammeter and ignition switch to the coil primary winding, then to ground.

The collapsing field induces a very high voltage in the secondary winding which is carried by the high tension wire to the center terminal of the distributor cap. The rotor connects this center terminal to one of the cap terminals which in turn is connected to the proper spark plug.

The spark produced by this high tension current ignites the fuel in the cylinder. This process is repeated for every power stroke of the engine and at high speeds, an impulse may be required as often as 300 times per second.

**Ignition Coil** — The function of the ignition coil is to transform the low voltage supplied by the battery into the high voltage to jump the spark plug gap.

An ignition coil has two windings wound on a soft iron core; the primary winding which consists of a comparatively few turns of heavy wire, and the secondary winding of many thousand turns of very fine wire. The primary winding is wound around the outside of the secondary winding. A soft iron shell encloses the outside of both windings and serves to complete the magnetic circuit.

Ignition coils do not normally require any service except keeping all terminals and connections clean, and tight. The coil should be kept reasonably clean; however, it must not be sub-

jected to steam cleaning or similar cleaning methods that may cause moisture to enter the coil.

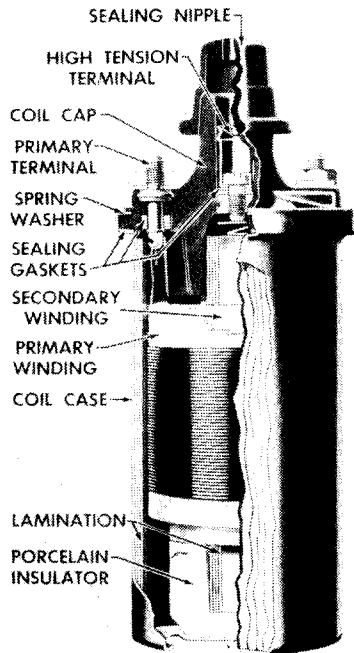

Cutaway View of an Ignition Coil

## ⚠ WARNING

Stop engine before checking battery terminals or electrical connections. Do not hold ignition wires with bare hands since shocks or other injuries can result. Sparks or flames near a battery could cause an explosion or fire. Battery acid can cause corrosive burns. Always wear eye protection. Use of jumper cables or battery charging should be done only as directed by manufacturers safety instructions.

Read and observe safety warnings on pages 1 and 2.

Ignition coils can be tested for grounded windings by placing one end of the test probe on a clean part of the metal outer shell and touching the other end of the test probe to the primary and high voltage terminals. If tiny sparks appear at the points of contact, the windings are grounded.

If the coil is further suspected of being faulty, remove and check its operation on a coil tester and replace it if inoperative. Most coil testers compare the operation of the coil being tested with one known to be in good condition. This test should be made with the coils at room temperature and then warming the coils five minutes by connecting the primary to a battery of the same voltage rating as the coils. Re-check the comparison test to see if the expansion due to heating has caused some defect.

The ignition coil center tower rubber "Boot" should always be replaced when a new coil is installed. Carbonized tracks in the rubber "Boot"

form when a coil fails due to a "burned tower" and if the rubber boot is not replaced, early failure of the new coil can be expected.

When the ignition coil is wired up incorrectly with the distributor, it can cause high speed missing, loss of power and performance under heavy loads.

**Distributor** — The distributor conducts and interrupts the current through the primary winding of the ignition coil at the correct time and distributes the high tension voltage to the correct spark plug.

There are two separate electrical circuits in a distributor. The sensor and trigger wheel device are in the primary circuit and carry low voltage current — while the cap and rotor are in the secondary circuit and carry the high voltage spark current.

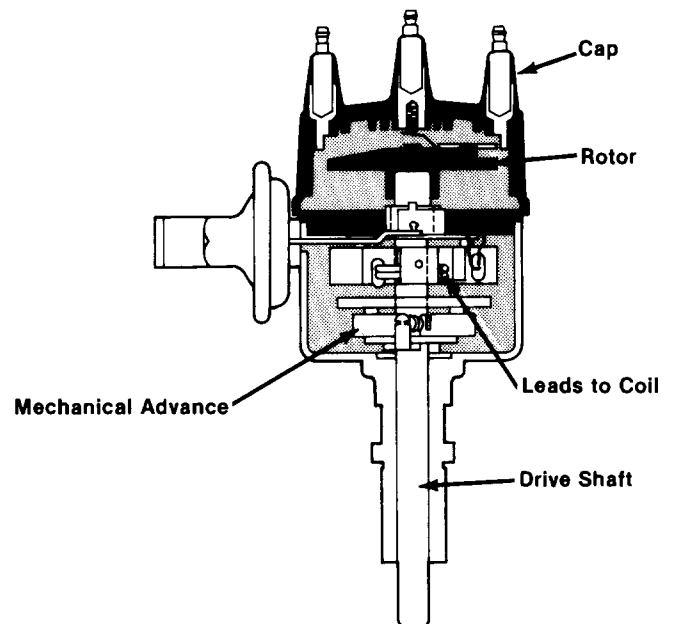

Cutaway View of Distributor

The triggering system is mounted on a plate in the top part of the distributor housing.

The rotor is mounted above the triggering system and turns with it to make a connection between the cap center contact and various side contacts.

Continental industrial engines have distributors equipped with a mechanical advance which varies the timing by advancing the breaker cam as the engine speed increases. This mechanism consists of weighted levers which revolve with the distributor rotor and act against a set of springs. As the speed of rotation increases, the weights are moved out and the timing is advanced. With this arrangement it is possible to have a retarded spark for idling and obtain a

gradual advance in spark timing as the engine speed is increased.

The ignition system also features vacuum advance for optimum part throttle economy. With this system spark timing is not only adjusted for the rotating speed but also for the load applied to the engine. As load is decreased, timing is advanced, and as load is increased, timing is retarded until only the mechanical advance is used.

**DISTRIBUTOR MAINTENANCE** — The distributor operation is vital to the operation of the engine and the following items should be carefully inspected every 250 hours of normal operation; however, dirt, dust, water and high speed operation may cause more rapid wear and necessitate more frequent inspections:

1. **Remove Distributor Cap** — Clean cap and examine for cracks, carbon runners, corroded terminals or if the vertical faces of the inserts are burned — if found, install a new cap. If the horizontal faces of the inserts are burned — replace the cap and rotor as this is due to the rotor being too short.
2. **Check Mechanical Advance Mechanism** for “freeness” by turning the breaker cam in the direction of rotation and then releasing it. The advance springs should return the cam to its original position.
3. **To ensure proper operation**, the diaphragm in the vacuum advance unit and the line to the manifold should be checked periodically for leakage. If the diaphragm is ruptured, the vacuum advance housing and linkage must be replaced.

**SPARK PLUGS** — A spark plug consists of two electrodes; one grounded to the outer shell of the

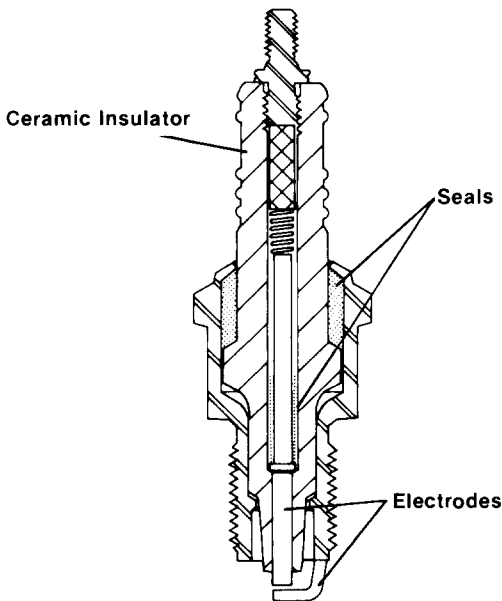

Sectional View of Spark Plug

plug and the other well insulated with a core of porcelain or other heat resistant material. The space between these two electrodes is called the gap which should be set at 0.8mm (.032”) for Continental OHV engines. Correct and uniformity of the gaps of all spark plugs in the engine is important for smooth running.

Spark plug gaps are best checked with a wire gauge unless the points are dressed to obtain a correct reading with a flat gauge. The adjustment should always be made on the side electrode and never on the center electrode which may cause a broken porcelain.

“Gapping” the electrode tip is more easily done with proper tools.

**GAPPING THE SPARK PLUG.** This illustration shows the use of the gapping tool which both measures and adjusts the electrode gap.

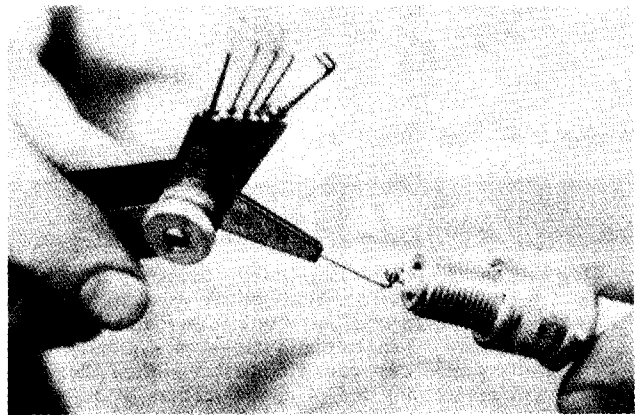

Checking Spark Gap

Spark Plugs must operate within a certain temperature range to give good performance — not too hot and not too cold. The ability of a spark plug to conduct heat away from the center electrode and porcelain is controlled by the design of the shell and insulator — so varying the length of the insulator below the gasket shoulder controls the temperature.

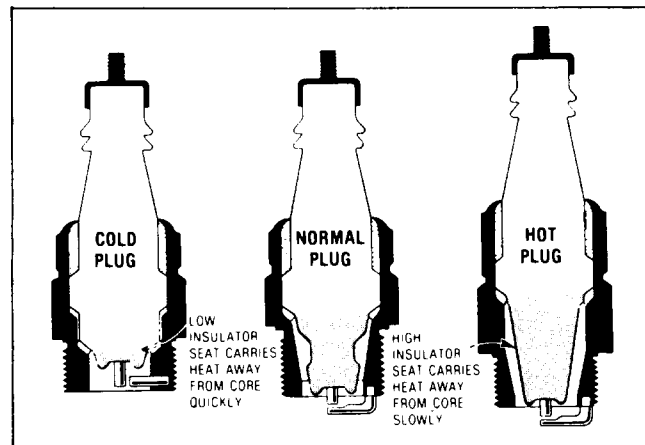

## Cold - Normal - Hot Spark Plugs

Examination of a used spark plug will show if it is in the correct heat range for the operating conditions. If the plug runs too hot, the insulator will blister or crack and the electrodes burn away rapidly. If the plug remains too cool — soot and carbon will deposit on the insulator causing fouling and missing.

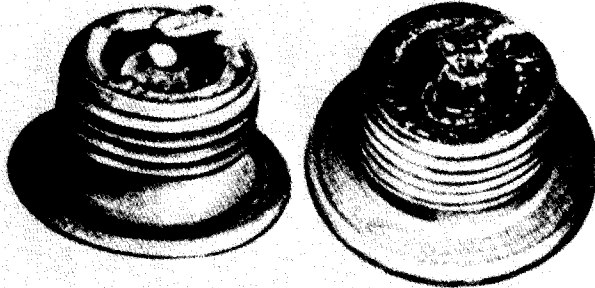

Faulty Spark Plugs. Left: cold plug used in an engine that should have a hot plug. Right: hot plug used in an engine that should have a cold plug.

Spark plug electrodes will wear in the course of time and present day fuels have a tendency to form rusty-brown oxide deposits on the insulator tip. Therefore it is necessary to periodically clean the plugs with a plug cleaner and to reset the gaps to specifications.

Spark plugs must be correctly installed in order to obtain good performance from them. It is a simple but important matter to follow the following procedure when installing plugs:

1. Clean the spark plug seat in the cylinder head.

2. Use new seat gasket and screw plug in by hand.
3. Tighten all 14mm plugs to 40 Nm (30 LB. FT.) torque with socket wrench of correct size.

## DISTRIBUTOR IGNITION TIMING

With Timing Light

Normally Continental industrial engines with distributor-ignition are timed to have the distributor points start to open when #1 cylinder is on compression stroke and the flywheel mark 2°BTDC (Before Top Dead Center) and (5°BTDC for LPG engines) lines up with the pointer in the bell housing or crankshaft pulley.

**NOTE:** Some special units have different ignition timing. Check your specification for correct timing.

**CAUTION:** Before ignition timing can be checked or adjusted, remove the vacuum advance line at the distributor and clamp the rubber tube leading to the intake manifold.

After setting the timing, remove the clamp and reconnect the rubber tube to the vacuum advance unit on the distributor.

To ensure proper operation the diaphragm in the vacuum advance unit and the line to the manifold should be checked periodically for leakage. If the diaphragm is ruptured, the vacuum advance housing and linkage must be replaced.

There are two methods of checking ignition timing — *with or without a timing light*.

The *preferred method* is to use a timing light in the following sequence:

Paint a line on the flywheel (or in some cases, on the front pulley) so the timing mark will be more legible under the timing light.

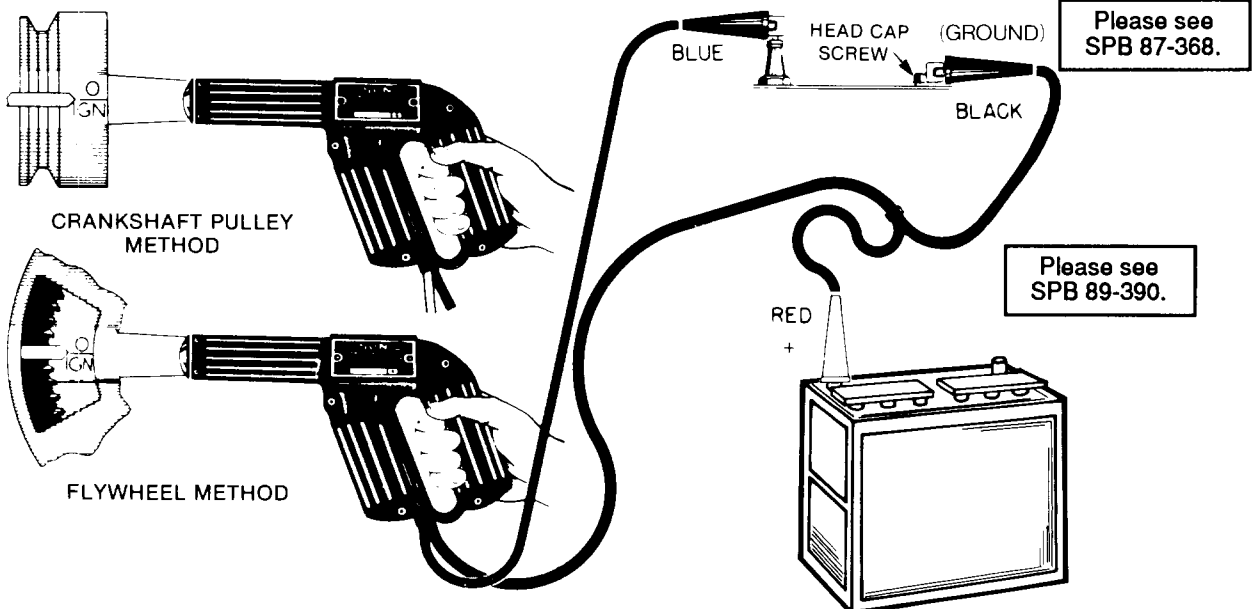

Schematic Diagram Showing Typical Timing Light Hookup



## WARNING

Disconnect fan before timing engine to avoid personal injury.

Do not hold ignition wires with bare hands since shocks or other injuries can result. Sparks or flames near a battery could cause an explosion or fire. Battery acid can cause corrosive burns. Always wear eye protection. Use of jumper cables or battery charging should be done only as directed by manufacturers safety instructions.

Read and observe safety warnings on pages 1 and 2.

1. Clip blue secondary lead of light to the #1 spark plug — leave spark plug wire on plug.
2. Connect primary positive lead (red) to positive terminal of battery.
3. Connect primary negative lead (black) to cylinder head capscrew or alternator bracket. Disconnect vacuum line from distributor to manifold and clamp end of line leading to the manifold.
4. Start engine and run at idle speed, 400 R.P.M. or lower, so the automatic advance of the distributor is completely retarded. **THIS IS VERY IMPORTANT TO OBTAIN CORRECT TIMING.**
5. Direct timing light on the crankshaft pulley or on the flywheel through opening in bell housing and note timing marks as light flashes.
6. Timing is normally at 2°BTDC unless specified otherwise on your engine specification sheet.
7. To advance timing, turn distributor body clockwise. To retard timing, turn distributor body counter-clockwise.
8. When timing is correct, tighten distributor clamp screw securely. Then re-check timing again with light.
9. This operation is best performed in a **shaded area**, so timing light is visible.

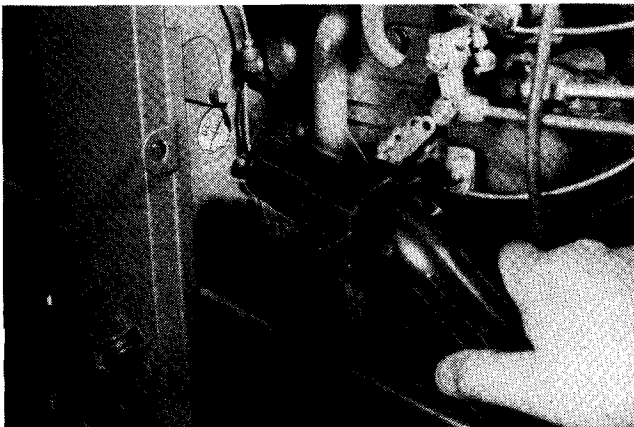

Checking Flywheel Timing with Timing Light

### DISTRIBUTOR IGNITION TIMING Without Timing Light (Emergency Method)

1. Remove #1 Spark Plug — put your thumb over the spark plug hole and crank engine by hand until air is exhausting.

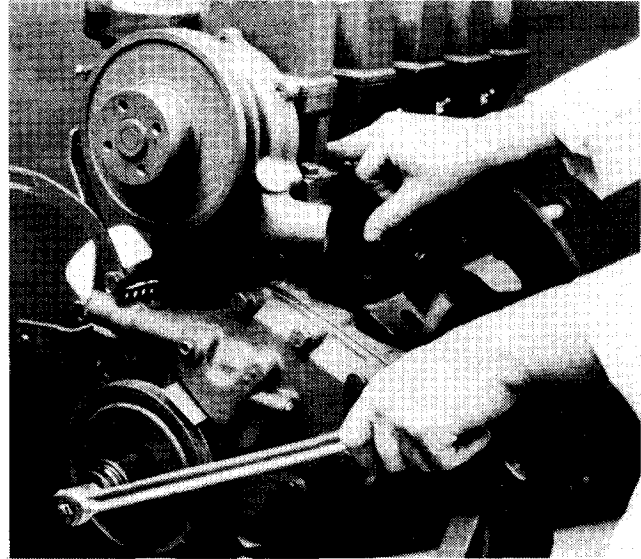

Checking No. 1 Cylinder on Compression Stroke

2. Set piston at 2°BTDC (5°BTDC for LPG engines) by slowly cranking until correct mark on flywheel (or crankshaft pulley) will line up with the pointer in bell housing (or gear cover).

**CAUTION:** When engine specifications have special timing other than 2°BTDC (Before Top Dead Center) — they must be followed in order to obtain satisfactory service in special applications or higher altitudes.

3. Loosen the distributor clamp bolt and install a test lamp on the two coil terminals, rotate the distributor until the light is extinguished, then clamp the distributor in place.

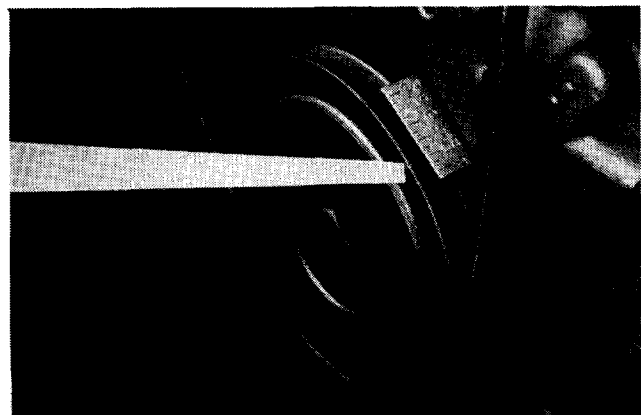

Crank Pulley Timing Mark

# CHARGING CIRCUIT

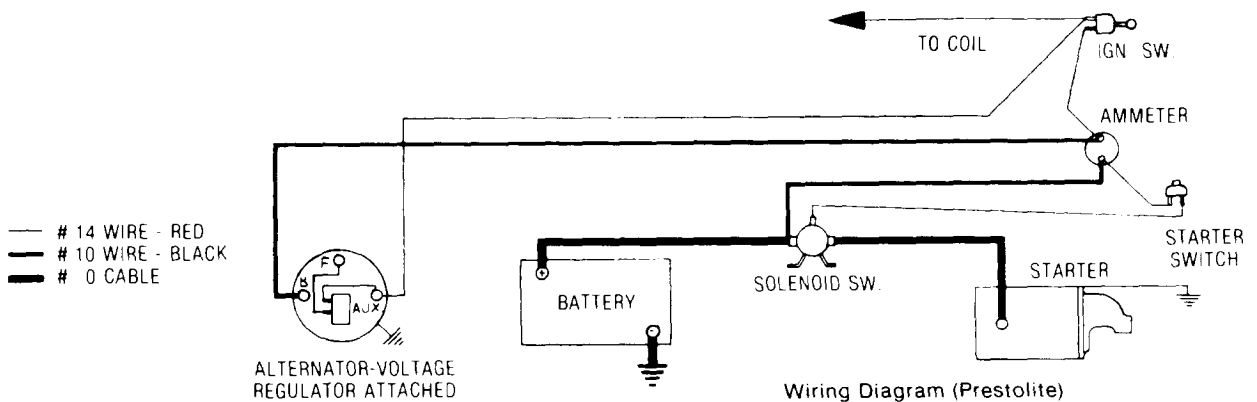
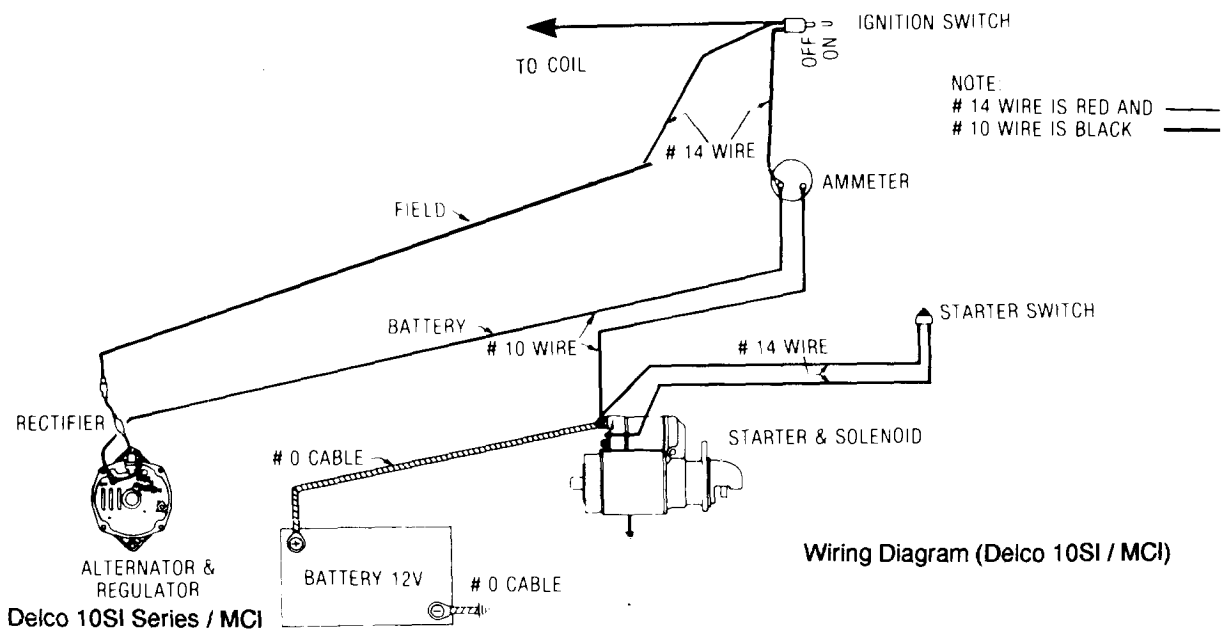
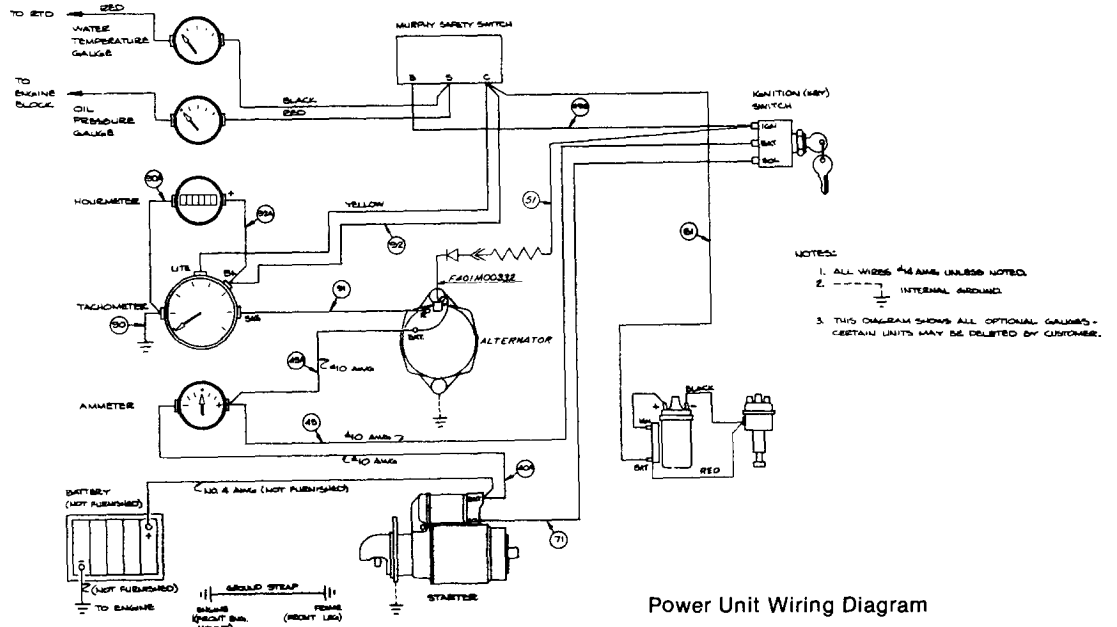

The charging circuit consists primarily of an alternator, regulator, battery and wiring. When analyzing the charging circuit, the components should be checked in the following order:

## I. Wiring

Wiring in the charging circuit should be carefully inspected for frayed insulation or other damage, and replace any wiring that is defective. Also inspect all connections to the alternator, regulator and battery (including all ground connections), and clean and tighten as required.

## II. Battery

The lead-acid storage battery, used on automotive and industrial applications, is an electrochemical device for converting chemical energy into electrical energy.

It has three major functions:

1. It provides a source of current for starting the engine.
2. It acts as a stabilizer to the voltage in the electrical system.
3. It can, for a limited time, furnish current when the electrical demands of the unit exceed the output of the generator.

# **WARNING**

Stop engine before checking battery terminals or electrical connections. Do not hold ignition wires with bare hands since shocks or other injuries can result. Sparks or flames near a battery could cause an explosion or fire. Battery acid can cause corrosive burns. Always wear eye protection. Use of jumper cables or battery charging should be done only as directed by manufacturers safety instructions.

Read and observe safety warnings on pages 1 and 2.

Refer to equipment manufacturer for battery recommendations.

## III. Alternator

The alternator differs from the conventional D.C. shunt generator in that the armature is the stationary member and is called the stator; while the field is the rotating member and is called the rotor. Alternating current is rectified (changed to direct current) by means of diode rectifiers rather than mechanically with brushes coming into contact with the various segments of the rotating armature on the generator. With this construction, the higher current values involved in the armature or stator may be conducted to the external circuit through fixed leads and connections rather than through the rotating commutator and brushes as in D.C. generator. The comparatively small values of current supplied to the field

may be conducted without difficulty through small brushes and rotating slip rings.

The alternator is somewhat lighter and more compact in design than the conventional D.C. generator of comparable electrical size and is equally as simple to service and test.

Each bearing is prelubricated which eliminates the need for periodic lubrication.

## Precautions to be observed when testing or servicing the alternator system:

1. **Disconnect the battery**, before connecting or disconnecting test instruments (except voltmeter) or before removing or replacing any unit or wiring. Accidental grounding or shorting at the regulator, alternator, ammeter or accessories, will cause severe damage to the units and/or wiring.
2. **To avoid damage to the regulator, do not, at any time, connect battery to the regulator field terminal.**
3. **The field circuit must never be grounded, on this system, between the alternator and the regulator.** Grounding of the field terminal either at the alternator or regulator will damage the regulator.
4. **If it is necessary to solder any lead to a rectifier lead**, use a pair of pliers as a heat dam between the solder joint and the rectifier.
5. **The alternator must not be operated on open circuit with the rotor winding energized.**
6. **Do not attempt to polarize the alternator.** No polarization is required. Any attempt to do so may result in damage to the alternator, regulator, or circuits.
7. **Grounding of the alternator output terminal may damage the alternator and/or circuit and components.**
8. **Reversed battery connections may damage the rectifiers, wiring or other components of the charging system.** Battery polarity should be checked with a voltmeter before connecting the battery.
9. **If a booster battery or fast charger is used, its polarity must be connected correctly to prevent damage to the electrical system components. (positive to positive, negative to negative.)**

## IV. Regulator

Most regulators are fully transistorized and completely sealed. These cannot be adjusted or repaired and it can be assumed that this type regular will outlive the other components in the charging system.

On current Delco/MCI alternators, the regulator is inside the alternator housing, and the case must be split to replace. Care should be taken in the operation to insure correct assembly.





**NOTES**

1

# Section 8 - Preventive Maintenance

In order to obtain maximum efficiency from your gasoline engine, a definite maintenance program should be set-up and followed. Haphazard maintenance will only lead to faulty engine performance and shorten engine life.

All moving parts in the engine are subject to wear; however, wear **can be reduced** by careful operation and a planned maintenance program.

In general, gasoline engine operation demands careful attention to the cleanliness of **air, fuel and oil** and maintaining coolant operating temperatures of 81°-93°C (180°-200°F.).

The following pages, covering **Daily, 50, 250 and 500** hour maintenance, have been worked out with our field service division as "Minimum Requirements" to keep your engine in dependable operating condition.

## DAILY PREVENTIVE MAINTENANCE SCHEDULE

### 1. OVERALL VISUAL INSPECTION OF ENGINE

Look for evidence of fluid leaks on floor, cylinder head and block, indicating loose fuel, oil or water connections — **tighten if found.**

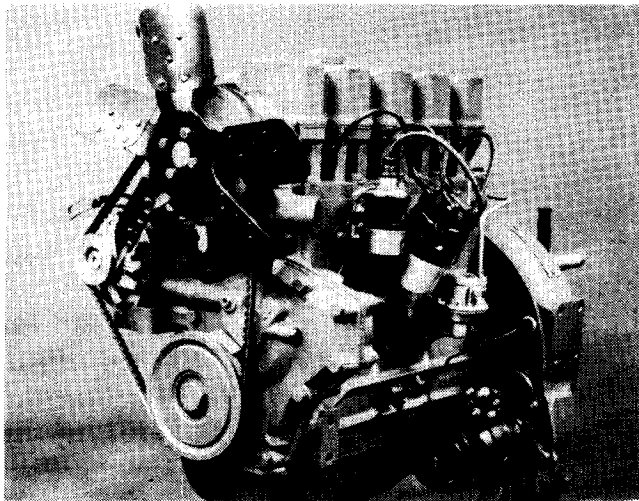

Check for Possible Leakage

### 2. CHECK OIL LEVEL OF ENGINE

The dipstick indicates the high and low oil level in the crankcase—make allowance for additional oil drainage back into oil pan if engine has not

been stopped 15 minutes. The most efficient oil level is between the two dipstick levels.

**IMPORTANT:** Do not add oil until oil level approaches the low mark — then add only enough to bring it to high level — **NEVER** above.

Do not operate the engine with oil below low level mark.

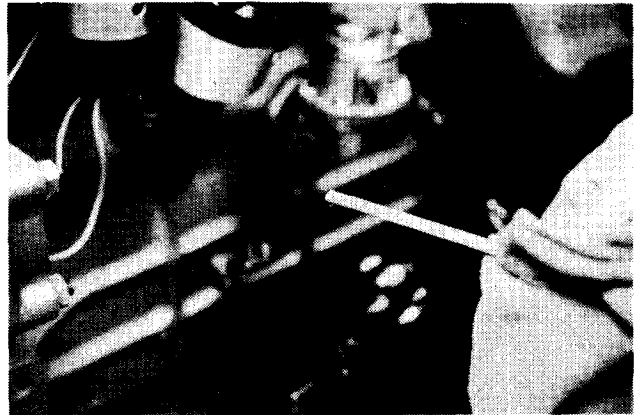

Check Oil Level of Engine

### 3. CHECK RADIATOR

Fill radiator with clean water or anti-freeze to normal level maintained due to expansion when heated. Visually inspect fan and belt for condition and adjustment.

### 4. FILL FUEL TANK

Fill fuel tank at end of each day's operation to prevent condensation forming in tank. Clean filler cap and area round spout before filling to prevent entrance of dust into fuel system.

### 5. CHECK AIR CLEANER

All engines, when operating, consume several thousand cubic feet of air per hour. Since dusty air is full of abrasive matter, the engine will soon **wear excessively** if the air cleaner does not remove the dust before entering the cylinders.

On any air cleaner, operating environment dictates the air cleaner service periods. In extremely dusty operations this may be once or twice daily. In dust protected areas the air cleaner should be serviced when changing oil.

Two basic types of air cleaners are normally used — the oil bath type and the dry replaceable element type.

## OIL BATH AIR CLEANER

The oil bath air cleaner must be given close and frequent attention. The efficiency of an oil bath cleaner is very closely linked to the amount and viscosity of the oil used. As dirt is strained from the air flowing through the cleaner, it thickens the oil in the cup and also raises the oil level in the cup. The proper method of servicing an oil bath air cleaner begins with pouring the old oil from the cup. Wipe the cup with a clean cloth. Refill the cup to the mark, being careful not to exceed this line. It is generally recommended to use SAE-20 oil in the summer and SAE-10 oil or lighter in winter.

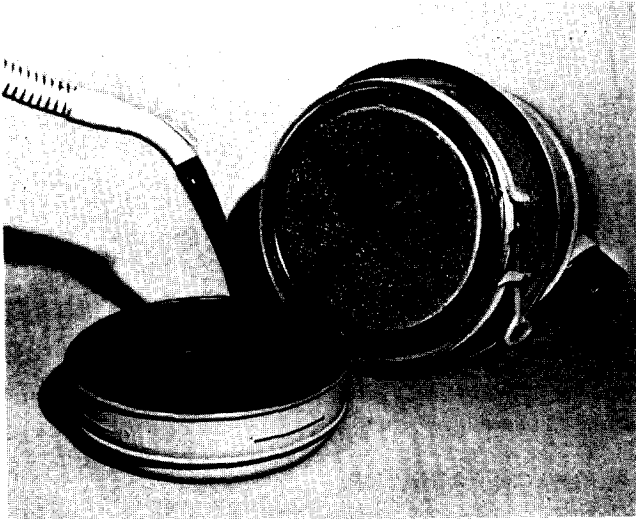

Fill Oil Bath Air Cleaner Cup to the Indicated Mark.

### 1. SERVICING REMOVABLE PRE-FILTER

Some oil bath air cleaners have removable pre-filters - which stop all lint, chaff and fibrous material that enter.

**Remove the pre-filter every time the air cleaner is serviced**, and wash out all chaff or dust in a solvent.

### 2. SERVICING MAIN FILTER ELEMENT

This filter element is made up of thousands of steel springs, interlocked and compressed to a mass of uniform density - which traps the oil and completes the cleaning process.

**Normal service** - completely remove the air cleaner every **4-6 months** - remove the bottom half and pre-filter then immerse and back flush the main filter element with a cleaning solvent.\*

**Severe service** - will require cleaning of this element **ev ry week** or more frequently if required.

\*Be sure element is dry of all cleaning solvent before reassembling.

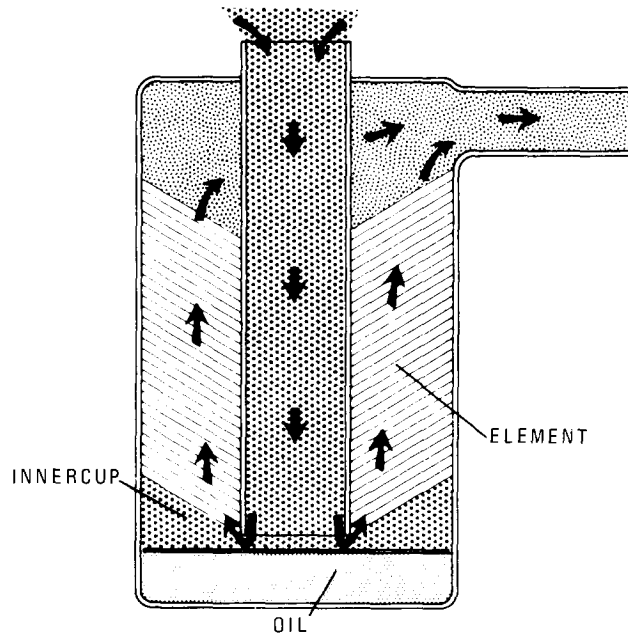

Sectional View of Oil Bath Cleaner

**CAUTION:** Do not steam-clean or use high pressure air to clean the filter element as it opens a direct channel through the filter - which permits oil, as well as dirt, to pass directly through the oil bath cleaner.

## DRY TYPE REPLACEABLE AIR FILTER

Dry type air filters are optional equipment on many engines and it is most important that the dirt buildup in the cartridge does not reduce the air flow sufficient to cause a noticeable loss in power.

They should normally be serviced every 50 hours in the following steps: (Extreme conditions will require daily cleaning.)

Remove cover and cartridge after removing wing bolt - do not allow dirt to fall into the exposed carburetor.

Clean cartridge by gently tapping flat on a smooth horizontal surface to shake out the dust.

## **WARNING**

Wear protective glasses or a face protector whenever air hoses are used. Never use air pressure that is more than 2 Bar (30 pounds per square inch) and make sure the air line is equipped with a water filter to prevent damage to parts.

Read and observe safety warnings on pages 1 and 2.

Cartridge can be cleaned best by blowing compressed air from inside out. Do not apply air closer than 50mm (2") and don't use more than 2 Bar (30 PSI) pressure.

**CAUTION:** Do not damage gasket surface or bend outer screen.



Wipe inside screen, cartridge gasket surface, inside cover and mounting seat before installing element.

Place cartridge on mounting seat - make sure outer edge of cartridge fits inside edge of bottom plate.

Replace cover and assemble wing bolt finger tight to insure air filter seal.

**CAUTION:** Do not wash or oil cartridge.

### Replacing New Cartridge.

Replace immediately if bent, crushed or damaged. Dry type air cleaners are efficient only as long as top and bottom sealing edges are not damaged.

Also surface of air cleaner base and cover where air cleaner cartridge seals, must be clean and not damaged, such as dents or bends.

Often in cleaning the cartridge it is tapped against surfaces that are not flat, thus damaging sealing edges. Regardless of how clean the paper is, **if edges are damaged dirt will enter the engine.**

The element should be replaced every 250 hours or when servicing does not result in full power recovery - whichever occurs first.

Under extreme dust conditions more frequent replacement will be required. Replace when power loss remains after servicing or when the intake manifold vacuum exceeds 250mm (10") water, using a good water manometer (mechanical vacuum gauges read in mercury and 25mm (1") is equivalent to 346mm (13.6") of water).

A ¼ Teaspoon of Dust per Hour Can ruin an Engine in One 8 Hour Day

### PCV SYSTEM

All connections must be air tight.

Blow-by circulates into the intake manifold maintaining crankcase pressure within a narrow range regardless of operating speed or load.

Servicing of the PCV system is usually confined to cleaning the PCV orifice and/or valve along with cleaning the air inlet, where applicable.

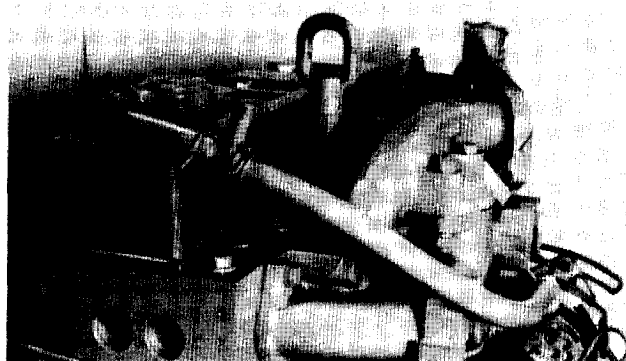

Typical Continental Motors PCV System Installation

### CHECK OIL PRESSURE\*

Note oil pressure gauge which should indicate the following pressure range at full throttle and a minimum of 0.5 Bar (7 pounds) pressure at idling speed.

MODEL	OIL PRESSURE
TM	2.8 - 4.1 Bar (40 - 60 PSI)

\*Standard Engines: on some special customer specifications, this may change. Higher oil pressures may be experienced during cold starts.

## NOTE ANY UNUSUAL NOISE

Operators familiar with daily engine operation soon become alert to any noise not normally present. This is very valuable in correcting defects in the early stages and preventing expensive repairs or delays.

## EVERY 50 HOURS

### 1. REPEAT DAILY OPERATIONS OUTLINED

Follow previous Instructions.

### 2. CHANGE CRANKCASE OIL

Engine life is dependent upon clean oil being circulated to all moving parts; therefore, the frequency of oil changes and oil filter replacement is very important and should be made at regular, scheduled periods.

The schedule for changing oil is directly dependent upon the operational environment: an extremely clean operation could go 150 hours while a dirty operation (foundry or cement factory) could be 50 hours or less.

Replace the oil filter element every time the oil is changed.

Thoroughly clean the filter, cover and sealing surfaces before replacing new element and gasket.

**Do not put kerosene into the crankcase.** The best method is to drain the oil when the engine is thoroughly heated — which will carry off most of the sediment.

Some operators unwisely put kerosene in the crankcase after draining the engine oil, then turn the engine over with the starter—In the belief they are doing a better job of crankcase cleaning.

In doing this, kerosene is circulated through the oil pump, the main oil header and the branches leading into the engine bearings—thereby washing away the protective oil film. In addition some of the kerosene will be trapped and remain to thin out the new oil, reducing its lubricating qualities.

### 3. SERVICE AIR CLEANER

If oil-bath air cleaner is used, remove bottom half of air cleaner—clean thoroughly and fill with engine oil to oil level mark on cup, avoid overfilling. Replace cup and check all connections to manifold. Be sure that no unfiltered air can enter the engine intake manifold.

If a dry type air cleaner is used, clean element with compressed air. **(See Daily Instructions)**

### 4. CHECK FAN BELT TENSION

Inspect wear condition of fan belt; note alignment and check belt tension which should allow not over 13mm (1/2") deflection on the long span.

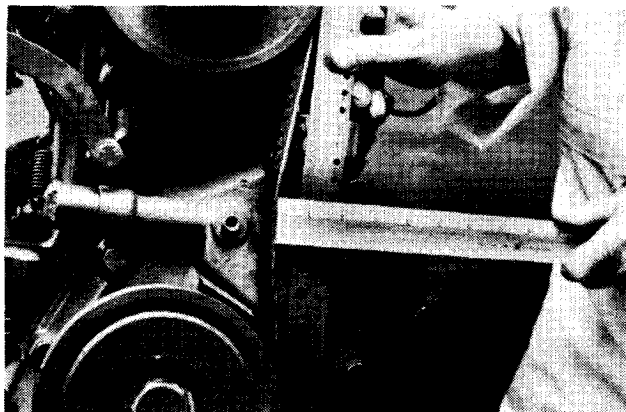

Fan Belt Tension

### 5. CHECK BATTERY

## **WARNING**

**Stop engine before checking battery terminals or electrical connections. Do not hold ignition wires with bare hands since shocks or other injuries can result. Sparks or flames near a battery could cause an explosion or fire. Battery acid can cause corrosive burns. Always wear eye protection. Use of jumper cables or battery charging should be done only as directed by manufacturers safety instructions.**

**Read and observe safety warnings on pages 1 and 2.**

Check specific gravity of each cell — which should be at least 1.250. Add distilled water, if required, to raise level 9.5mm (3/8") above the separators.

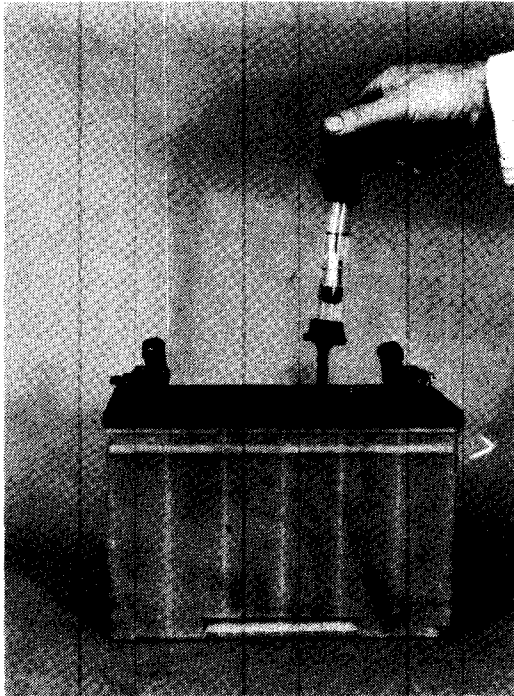

Checking Battery

Particular attention should be given the battery during cold weather. The cranking power of a fully charged battery @ 27°C (80°F.) is reduced 60% @ -18°C (0°F.) yet the power required to crank the engine is 2 1/2 times greater at -18°C (0°F) than @ 27°C (80°F.).

**6. TORQUE DOWN CYLINDER HEAD TO SPECIFICATIONS IN MANUAL.**

**7. ADJUST IDLE MIXTURE FOR HIGHEST RPM AND RESET IDLE SPEED TO 400-600 R.P.M. AND 800-1000 R.P.M. ON THE 2-CYLINDER ENGINE.** Repeat again at end of 500 hours.

**EVERY 250 HOURS**

**1. REPEAT DAILY AND 50-HOUR SCHEDULES**

Follow previous instructions.

**2. CLEAN EXTERIOR OF ENGINE**

Use steam if available, otherwise any good commercial engine cleaner to wash down the engine.

**3. CHECK GOVERNOR CONTROL**

Clean and lubricate all governor linkage to insure free operation of governor. Free-up any joints that may be binding or rods or levers that may be twisted. Check for full throttle opening.

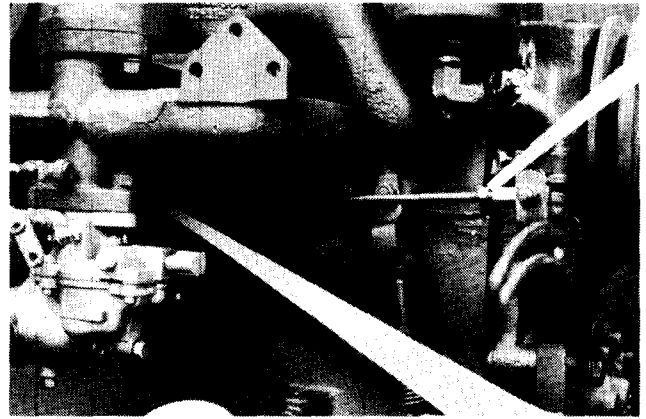

**4. CLEAN SPARK PLUGS**

Clean depressions around plugs before removing them — then clean and re-set electrode gap to 0.8mm (.032") on standard plugs.

Install spark plugs (14mm) and tighten to 40 Nm (30 Lbs. Ft.) torque.

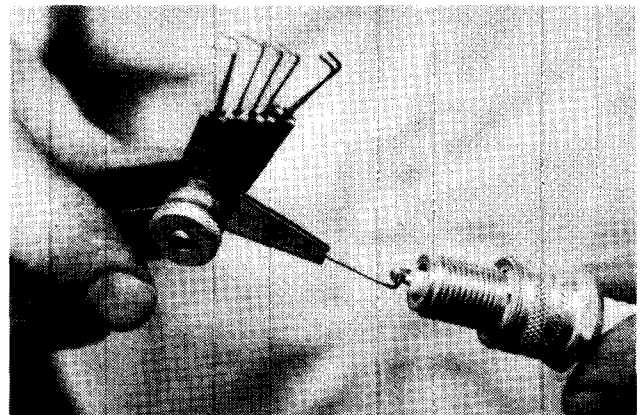

Re-Set Spark Plug Gap

**5. CHECK DISTRIBUTOR**

Remove Distributor Cap — Clean cap and examine for cracks, carbon runners, corroded terminals or if the vertical faces of the inserts are burned — if found, install a new cap. If the horizontal faces of the inserts are burned — replace the cap and rotor as this is due to the rotor being too short.

Check Mechanical Advance Mechanism for "freeness" by turning the breaker cam in the direction of rotation and then releasing it. The advance springs should return the cam to its original position.

To ensure proper operation, the diaphragm in the vacuum advance unit and the line to the manifold should be checked periodically for leakage. If the diaphragm is ruptured, the vac-

cuum advance housing and linkage must be replaced.

Check distributor clamp bolt and if found loose — retiming the engine is necessary.

The Electronic Ignition Distributor requires no adjustments due to the elimination of the points and condenser. A sensor and trigger wheel device replace the points and condenser in the distributor and provide the precise timing needed to fire the plugs. It is not repairable and if necessary must be replaced as a complete assembly.

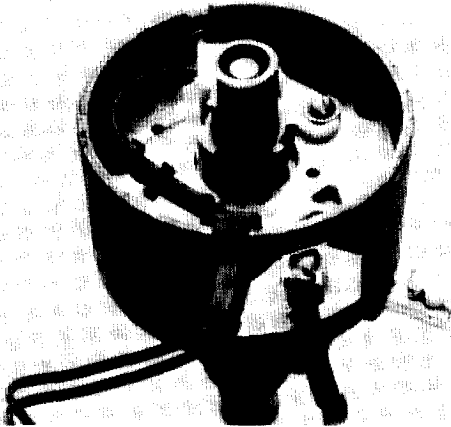

## WARNING

Stop engine before checking battery terminals or electrical connections. Do not hold ignition wires with bare hands since shocks or other injuries can result. Sparks or flames near a battery could cause an explosion or fire. Battery acid can cause corrosive burns. Always wear eye protection. Use of jumper cables or battery charging should be done only as directed by manufacturers safety instructions.

Read and observe safety warnings on pages 1 and 2.

### 6. INSPECT IGNITION WIRES AND CONNECTION.

Examine ignition wires for breaks in insulation, chafing and loose connections. Replace if defective.

### 7. IF DRY REPLACEABLE ELEMENT AIR CLEANER IS USED, REPLACE ELEMENT.

## EVERY 500 HOURS

#### 1. REPEAT DAILY — 50 HOUR AND 250 HOUR SCHEDULES

#### 2. COOLING SYSTEM

Clean radiator core by blowing out with compressed air.

Inspect radiator mounting.

Inspect water pump and connections for leaks.

Check fan and accessory drive belts.

### 3. ADJUST VALVE TAPPET CLEARANCE

Check and adjust intake and exhaust valve tappets to following clearances at idling speed and running temperature:

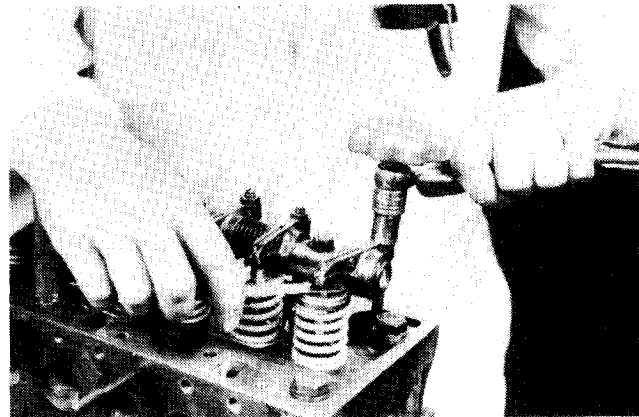

Adjusting Valve Tappet Clearance

MODEL	INTAKE	EXHAUST
TM	0.36mm (.014")	0.46mm (.018")

### 4. CARBURETOR

Clean exterior and check mounting to manifold.

Adjust carburetor air adjustment for even running and adjust idle speed to 400-600 R.P.M. minimum (800-1000 R.P.M. on 2-cylinder engine).

Inspect throttle and choke linkage for free operation.

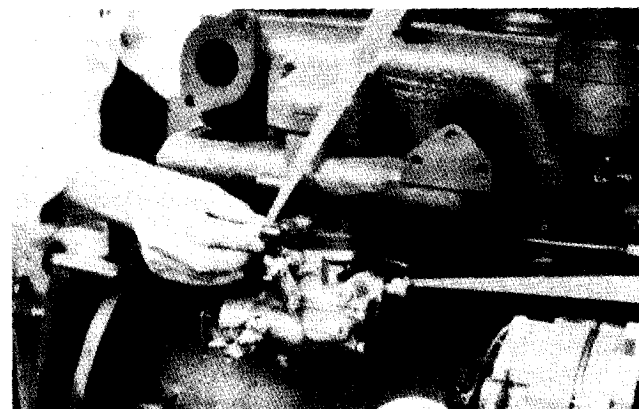

Carburetor







# Section 9 - Engine Repair and Overhaul

This section includes instructions for repairs and overhaul of the component units of Continental industrial engines.

Provide a clean place to work and clean the engine exterior before you start disassembling — *dirt causes engine failures.*

Many shop tools have been developed to save time and assure good workmanship; these should be included in your equipment.

Use only genuine Continental parts in Continental engines since years of development and testing have gone into these specifications to assure maximum life and performance.

## CYLINDER HEAD

The cylinder head is an important part of the engine assembly since it contains the combustion chamber, valves, and cored passages for air, exhaust and water flow.

### REMOVING THE CYLINDER HEAD

1. Drain water from engine and disconnect radiator or heat exchanger hoses.
2. Remove cylinder head cover by removing the capscrews holding the cover to the cylinder head.
3. Remove rocker arm shaft assembly and push rods. Grip the push rods and snap them sideways out of the tappet sockets as shown in the illustration. This method serves to break the hydraulic connection and permits lifting the push rods out and leaving the tappets in place.



Removing Push Rod from Ball Socket of Tappet

**CAUTION:** Make a sketch showing the proper location of the cylinder head cap screws for use at reassembly.

4. Loosen and remove the capscrews holding the cylinder head to the block.
5. Lift the cylinder head off the engine and carry to a clean bench for further disassembly.

### DISASSEMBLY OF CYLINDER HEAD

1. Remove all carbon from combustion areas using scraper and wire brush.
2. Using a C type valve spring compressor, remove the valve spring retainer locks, retainers, rotors, springs and oil guards on valve stems — placing all parts in a container of solvent.

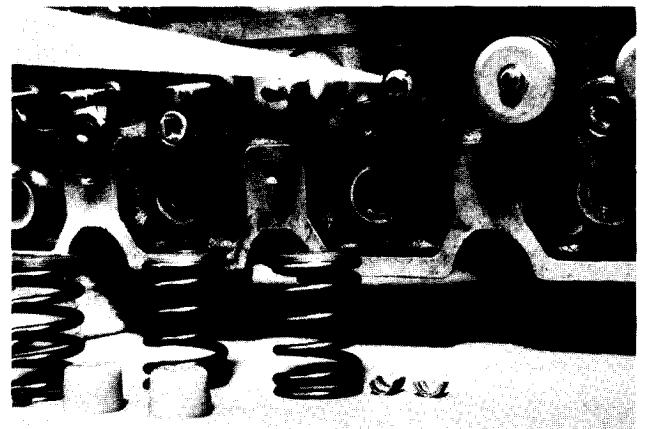

Removing Valve Springs

3. Remove the valves and place them in order in a rack with holes numbered for both intake and exhaust so they will not be mixed in handling.

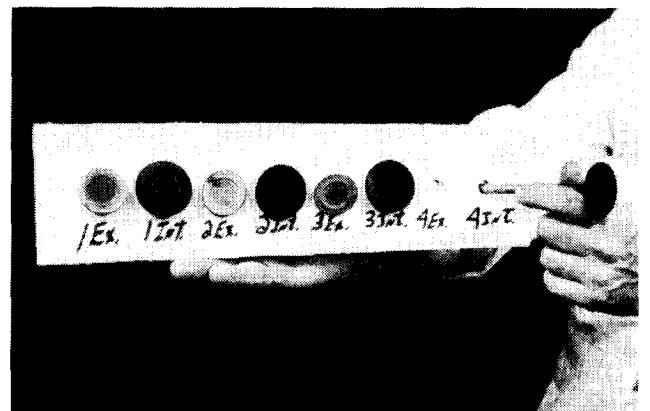

Valves in Rack

4. Clean the cylinder head thoroughly with a solvent or degreasing solution and blow it off with air pressure. Inspect carefully for cracks.

### VALVE GUIDES

1. Clean the valve stem guides, removing lacquer or other deposits. Do not use tools that remove metal.

2. Check guides for wear by using a telescope gage and 1" micrometer. Replace all guides that are worn bell-mouthed or have increased 0.038mm (.0015) in diameter. See Limits and Clearance Section 12 and Valve Guide Data, page 49, for maximum diameter permissible to determine actual amount it has increased. Remove all valve guides when necessary by pressing them out from the combustion chamber side.

3. Replace worn guides as required by pressing in new guides to the correct depth as given in the Section 12 limits and clearance data, and valve guide data, page 49.

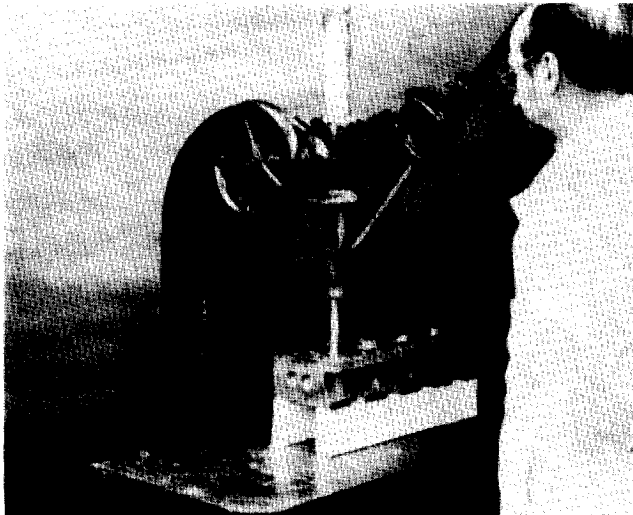

Removing Valve Guides from Combustion Chamber Side

**CAUTION:** When replacing guides do not ream since these are all pre-reamed before being ferrox coated—any further reaming will remove the coating.

### VALVE SEAT INSERTS (IF SUPPLIED)

1. The exhaust valve seat insert is held in place by a shrink fit.

Inspect all exhaust valve inserts in the head and replace any that are loose, cracked or otherwise damaged. Use puller for removing faulty insert.

2. When required to replace with new insert, clean and counterbore for 0.25mm (.010")

larger insert using counterbore tool with correct fitting pilot.

When machining the counterbore, be sure to go deep enough with the tool to clean up the bottom so that the insert will have full contact to carry away the heat.

Wis-Con Total Power does not recommend installing new inserts having the same outside diameter as the one removed. The following chart shows the dimensions of Standard Inserts and Counterbores:

### DIMENSIONS OF STANDARD INSERTS AND COUNTERBORES

Engine Model	Outside Dia. of Insert (A)	Inside Dia. of Counterbore (B)	Press Fit
TM	35.513mm	35.410mm	.077mm
	to 35.482mm	to 35.385mm	to .128mm
	(1.3981")	(1.3941")	(.003")
	to (1.3971")	to (1.3931")	to (.005")

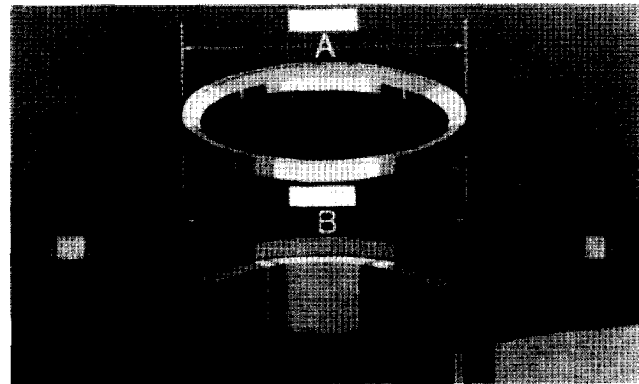

Insert and Counterbore

When OVERSIZE inserts are used, dimensions of the insert and counterbore increase proportionately 0.25, 0.50mm (.010", .020") depending on the oversize.



Chilling Inserts

## VALVE GUIDE DATA

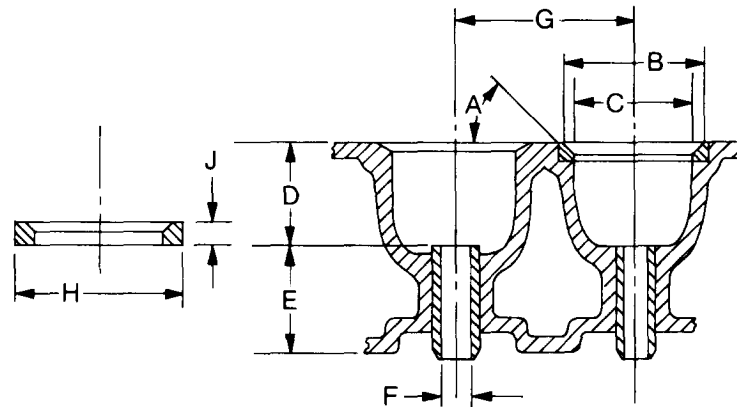

		Model TM	
		Intake	Exhaust
A	Valve Seat Angle	30°15'	45°15'
B	Diameter of Seat	41.26 (1.625)	34.26 (1.349)
C	Diameter of Choke	35.0 (1.38)	29.13/28.87 (1.147/1.137)
D	Distance	43.0 (1.69)	43.0 (1.69)
E	Length of Guide	60.4 (2.38)	60.4 (2.38)
F	Inside Diameter Guide	8.717/8.692 (.3432/.3422)	8.717/8.692 (.3432/.3422)
G	Distance Intake to Ex- haust	47.65 (1.876)	47.65 (1.876)
H	O.D. of Valve Seat Insert if Used	—	35.513/35.482 (1.3981/1.3971)
J	Thickness of Valve Seat Insert If Used	—	7.49/7.33 (.295/.288)
	Valve Seat Material If Used	—	SAE J-610

New insert installation must have a press fit. Chill insert in container with dry ice for 20 minutes before assembling.

Insert may then be installed in the counterbore using a piloted driver and arbor press, without the possibility of shearing the side walls. This assures it being seated firmly on the bottom of the counterbore.

- Grind the intake and exhaust valve seats in the head in accordance with instructions in the Valve Guide Data and limits and clearance chart. Before removing the arbor, indicate the seat. Total indicator reading of the run-out must not be more than 0.05mm (.002"). Use a pilot having a solid stem with a long taper, as all valve seats must be ground concentric and square with either new or worn valve stem guide holes.

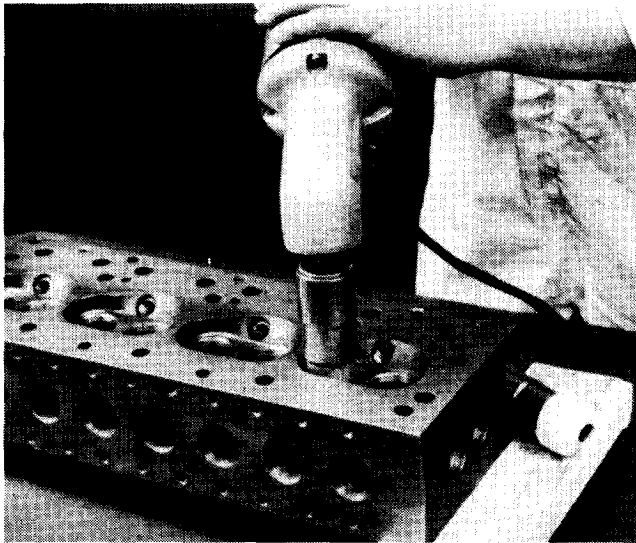

Grinding Valve Seat

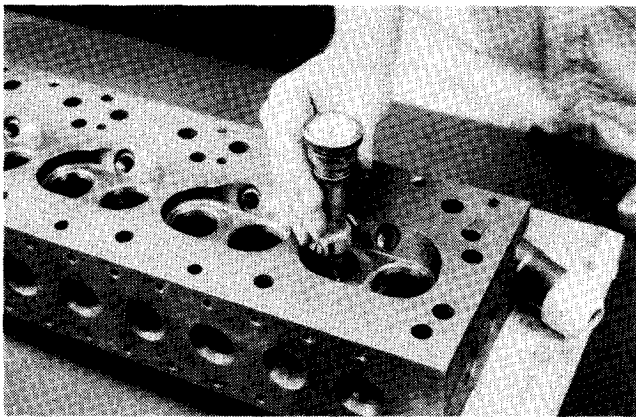

Indicating Valve Seat

## VALVES

1. Inspect valves for condition and replace any that are "necked", cracked or burned, also any on which valve stems are bent or worn more than 0.05mm (.002") over the maximum allowable limits. Reface or replace all valves.

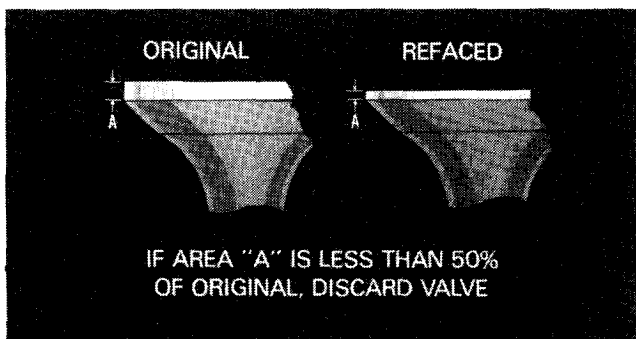

Allowable Head Thickness of Refaced Valves

2. All valves having less than 50% margin thickness (outer edge of valve head) after

refacing has been completed must be replaced. To check this dimension, compare the refaced valve with a new valve.

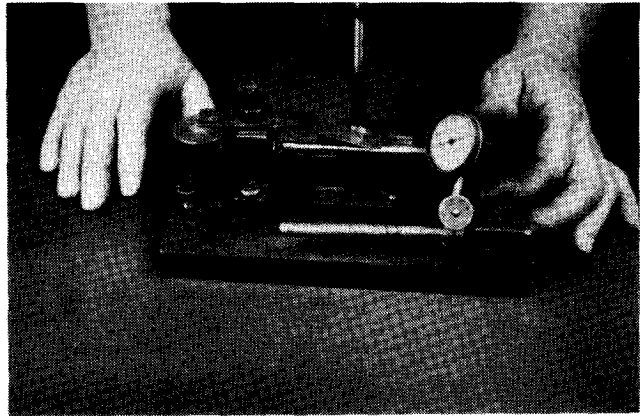

Checking Valve Face in "V" Blocks

3. Check all refaced or new valves in V-blocks with indicator to determine if the contact face is true with the stem within 0.05mm (.002"). If not, repeat the refacing operation.
4. After the valves and seats have been refaced and reground, coat the seat lightly with Prussian blue and drop the valve into position, oscillating it slightly to transfer the blue pattern to the valve face. This should show a contact width of 1.6 to 2.4mm (1/16" to 3/32") and should fall well within the width of the valve face, leaving at least 0.4mm (1/64") on either side where the blue does not show. If the contact is over 2.4mm (3/32") wide, the seat in the head may be narrowed by using a 15° stone to reduce the outside diameter or using a 60° or 75° stone to increase the inside diameter.



Checking for Proper Valve Seating

**Never allow valves to set down inside the seat.**

After the narrowed-down seat is brought within specifications, the seat should be

retouched lightly with the original stone to remove burrs or feathered edge.

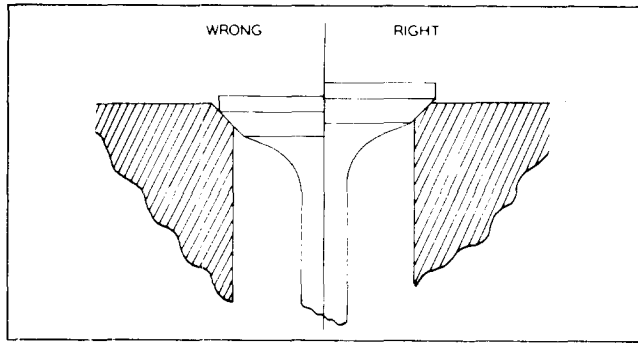

Valve Position in Head

**“A poor valve grinding job cannot be corrected by valve lapping.”**

For example, after the valve has been hand lapped, it would look like this when cold. The thin line visible here shows where the valve lapped into its seat. Keep in mind that the engine is now at rest and cold.

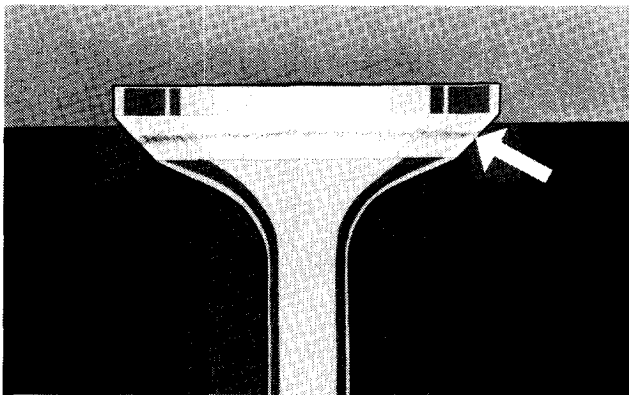

This illustration shows the same valve only now it has reached normal operating temperature. Notice that the lapped area of the valve and the seat no longer match each other. This is perfectly normal due to expansion of the valve. Now you can see that the effects of the lapping job are lost completely.

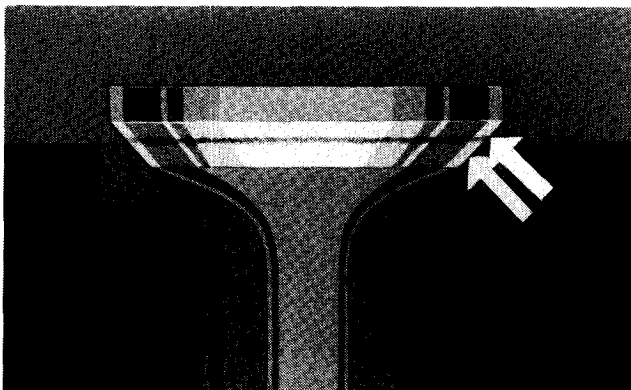

So remember . . . do not lap valves in after grinding.

5. Coat the valve stem with a light film of engine oil.

### VALVE SPRINGS

1. Check all valve springs on a spring tester to make sure they meet specifications regarding weight and length.

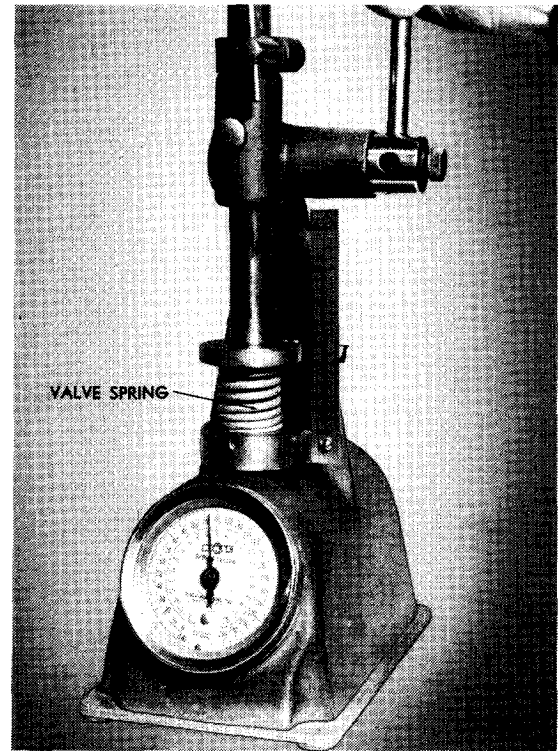

Valve Spring Tester

Springs, when compressed to the “valve open” or “valve closed” length, must fall within the specifications shown on the Limits and Clearance chart when new, and must not show more than 10% loss to re-use.

2. All intake and exhaust valves have oil guards. Soak in boiling water for several minutes prior to installation.

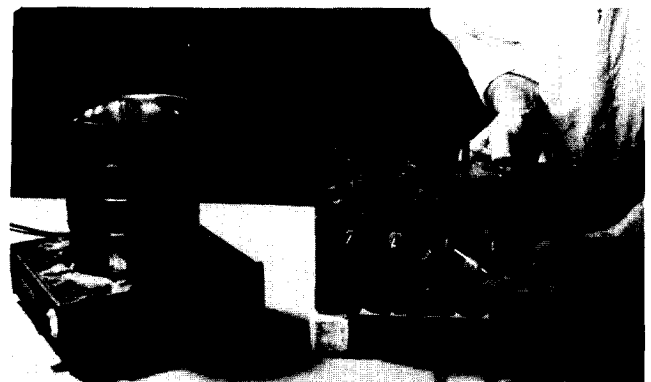

Installing Oil Guards

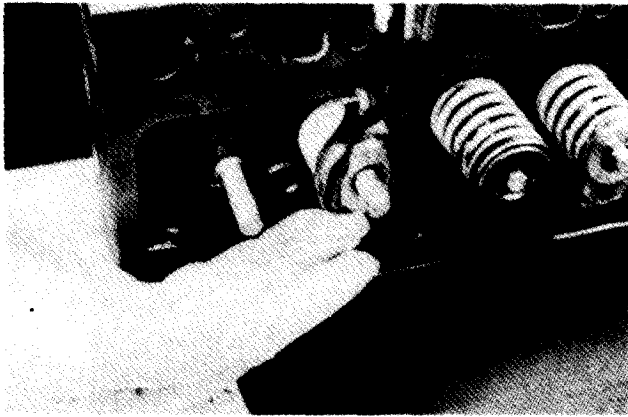

Valve Assembly

3. Reassemble the valves and springs in the head with the oil guards, retainer and retainer lock.

### ROCKER ARMS

1. Inspect the rocker arm shaft for wear. If the shaft has "shoulders" on it due to wear, replace. Blow out oil holes with air.
2. Examine rocker arms for cracks, condition of valve contact surface and worn bushings. Replace all defective rocker arms or any having over 0.13 mm (.005") clearance between shaft and arm.
3. Inspect the rocker arm brackets for cracks or other damage.

### VALVE PUSH RODS

1. Inspect push rods for bends or twist and examine the ball and cup ends for excessive wear. Replace rods that are faulty or excessively worn.
2. To prevent damage to push rods, replace after the cylinder head is installed.

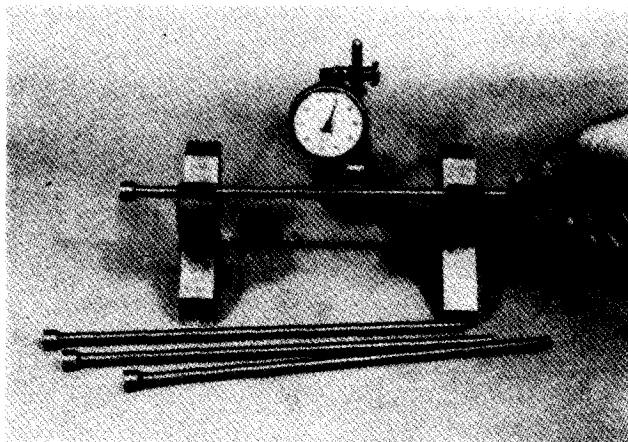

Push Rod Inspection for Runout

### CHECKING BORE WEAR

1. Clean the ring of carbon from around the top of the cylinder bore formed above the travel of the top ring.
2. Determine the original diameter of the cylinder barrel by checking this unworn area with a pair of inside micrometers at intervals of approximately 45°.



Measuring Original Bore Diameter Above Ring Travel

3. Check in same manner the top of the ring travel area approximately 6mm (1/4") below the shoulder.
4. The maximum difference in the above checks, indicates the amount of cylinder bore wear. If less than 0.20mm (.008"), re-ringing will be suitable and if over 0.20mm (.008") re-boring is recommended.

### PREPARING CYLINDER WALLS FOR RE-RINGING OR RE-BORING

1. Ridge ream the cylinders to remove the unworn area at the top so that the new rings when assembled will not bump and distort both themselves and the piston lands.

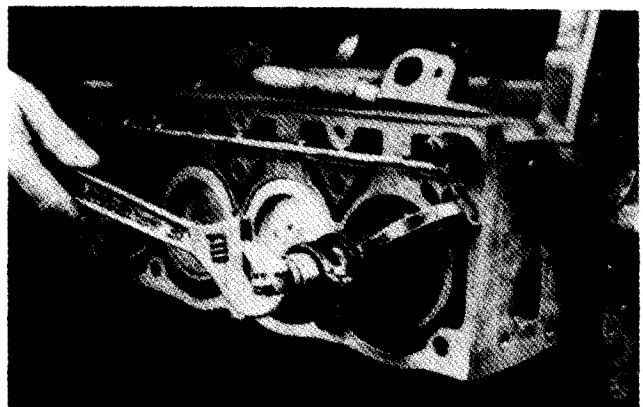

Ridge Reaming Top of Cylinder Bore

Several good makes of ridge reamers are available which will ream the top of the bore in direct relation to the worn area so that should the worn area be off center slightly there will be no partial ridge remaining.

2. Drain the crankcase and remove the oil pan.
3. Remove the cap screws holding the connecting rod caps to the rod. *Keep the cap and bolts in numerical order so that when the pistons and rods are removed from the engine, the cap can be reassembled and kept with its mating part.*
4. Push the pistons and connecting rods up through the top of the cylinder, carrying with them all the carbon and metal chips left from the cleaning and ridge reaming operation. *When doing this, every precaution must be taken to prevent damage to cylinder bores by the sharp corners and rough edges of the connecting rods.*
5. It is important to remove the glaze on the cylinder bores by using a cylinder hone, with an adjustable stone tension, in order to assure quick seating of the new piston rings. **If the cylinder glaze is not removed, you will have no assurance as to when the rings will begin to function properly and control the oil; this is especially true when chrome rings are used.**

The following step by step procedure is recommended:

- a. To get the correct cross hatch pattern with a cylinder hone, use a top quality electric drill with a speed of 500 R.P.M. or less and 280 grit stones.

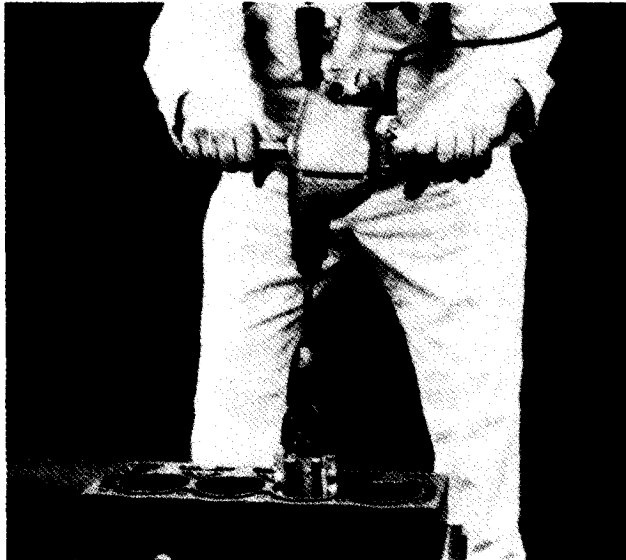

Honing Cylinders

- b. Cover the entire crankshaft with a clean, slightly oily cloth to prevent abrasives and dirt from getting on the crankshaft.
- c. Remove the excess carbon deposits from the top of the cylinder wall before beginning the glaze breaking operation. (This is to prevent loading the stones.)
- d. Insert hone in cylinder and expand to cylinder wall with slight tension. Using a clean brush, wet cylinder wall and stones with kerosene. Use a hand drill and surface hone cylinder with a rapid up and down motion to produce a good crosshatch pattern. Apply kerosene continuously and increase tension on hone adjustment until a good pattern and finish is obtained. A smooth finish of 0.25 - 0.38 micrometers (10 to 15 micro inches) is desired.

The honing operation will produce a sharp edge at the bottom of the bores. Upon completion of the honing operation, remove this sharp edge with a piece of number 500 emery cloth. If this edge is not removed, it can cause shaving of the piston skirts.

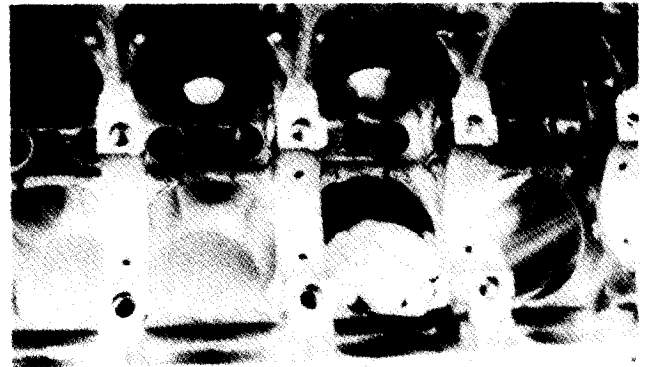

Removing Sharp Edge After Honing

- e. Clean the loose abrasives from the stones by using kerosene and a wire brush.

**IMPORTANT: Stones must be used wet.** Keep applying kerosene during honing to prevent stones from drying out and causing an incorrect honing pattern.

- f. The most desirable cylinder finish is 0.25 - 0.38 micrometers (10-15 micro inches); with this finish the depressions in the surface tend to keep a supply of lubrication between the mating parts. This finish can be obtained by using 280 grit stones on the hone.



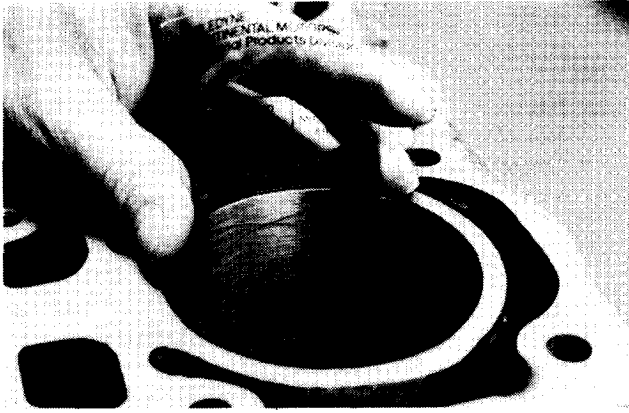

Desirable Crosshatch Pattern Obtained with a Cylinder Hone

After all honing operations are complete, thoroughly wash the bores with soap and water to remove all traces of grit. Kerosene or other solvents will not remove the grit. Rinse the block with clean, clear water and dry with compressed air.

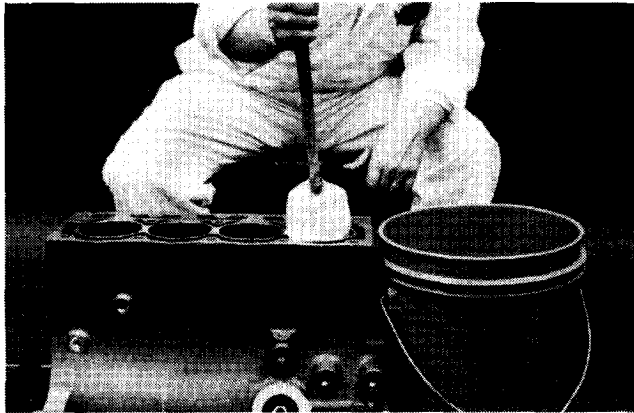

Cleaning Bores

When you have finished cleaning the block, run a clean, dry paper towel through the bores. The paper towel should come out clean.



Cleaning Block

If not, the bores must be rewashed. As soon as the bores have dried, lubricate with engine oil immediately to prevent rust. This completes the honing operation.

## PISTONS

Check the pistons for excessive ring groove wear, and replace any that exceed the allowable limits in our limits and clearance data.

The cylinder walls and pistons must be perfectly clean and dry when fitting pistons in the cylinder bores. Pistons should be fitted with the block and piston at room temperature 20.0°-21.0°C (68°-70°F).

PISTON FIT ON STANDARD PISTONS  
(with 2.3 to 4.5 kg (5 to 10#) Pull)  
TM series 0.08mm (.003")

Check the piston fit in the bore using a half-inch wide strip of feeler stock, of the thickness specified in the Limits and Clearance Chart, the feeler being attached to a small scale of approximately 7 kg (15 Lbs.) capacity.

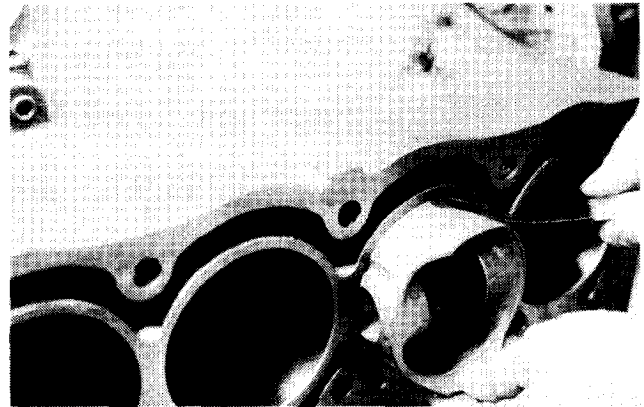

Checking Piston Fit in Bore

When the correct fit is obtained you must be able to withdraw the feeler with a pull of 2.3-4.5 kg (5-10 pounds) on the scale, with the feeler inserted between the piston and the cylinder midway between the piston pin bosses where the diameter of the piston is the greatest. Check the fit of the piston when it is approximately 50mm (2") down to the cylinder bore in an inverted position.

## PISTON PINS

Check the bushing in the upper end of the connecting rod for wear. If worn and you are using the original pistons with a service set of rings, an oversize piston pin may be obtained in 0.08 or 0.13mm (.003" or .005") oversize.

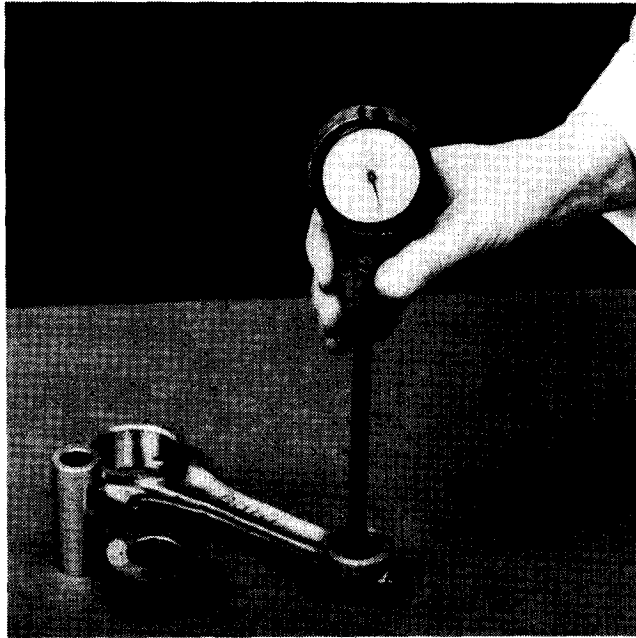

Checking Piston Pin Bushing for Wear

The piston pin hole in the piston and the bushing in the connecting rod may be honed to increase their diameter to obtain the desired fit as shown in your Limits and Clearance Chart.

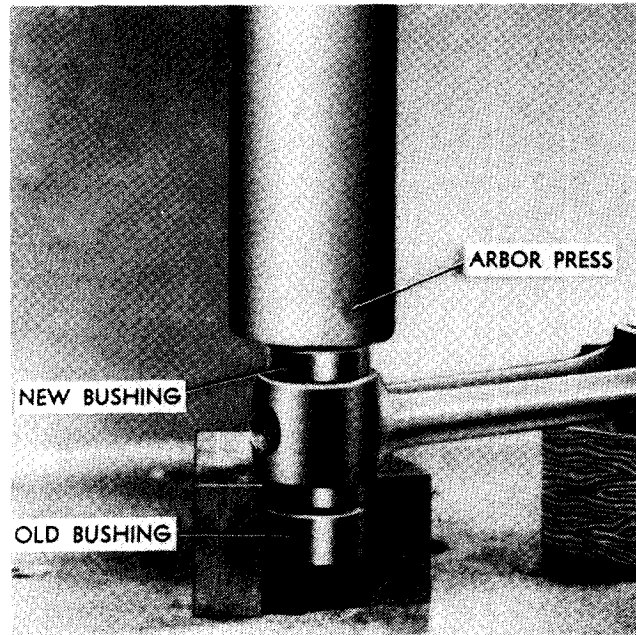

Pressing in Piston Pin Bushing

Note that while the chart specifies a light press fit of the pin in the piston, there is a definite clearance of the piston pin in the connecting rod.

## CONNECTING ROD

Replace the bushing in the connecting rod if new pistons and sleeves are used. Using the arbor

press, press out the old bushing and press in the new one making sure the oil supply holes line up—after which the bushing must be honed to obtain the correct fit of the pin in the bushing as shown on Limits and Clearance Chart.

If there is an excess of stock in the piston pin bushing, it may be reamed first, then honed. In any event, the final operation should be done with a hone to obtain the desired fit with better than 75% bearing area contact on the pin.

## PISTON AND CONNECTING ROD ASSEMBLY

1. Assemble the pistons on the connecting rod by first heating them in some form of oven or in hot water to a minimum temperature of 71°C (160°F.). When heated, the piston pin will enter the piston very easily and can be tapped through the connecting rod and into place without distorting the piston. The snap rings must be assembled in the grooves, making sure they are fully seated in place.

2. The piston pin hole in the connecting rod must be parallel to and in plane with, the large bore in the bearing end of the connecting rod.

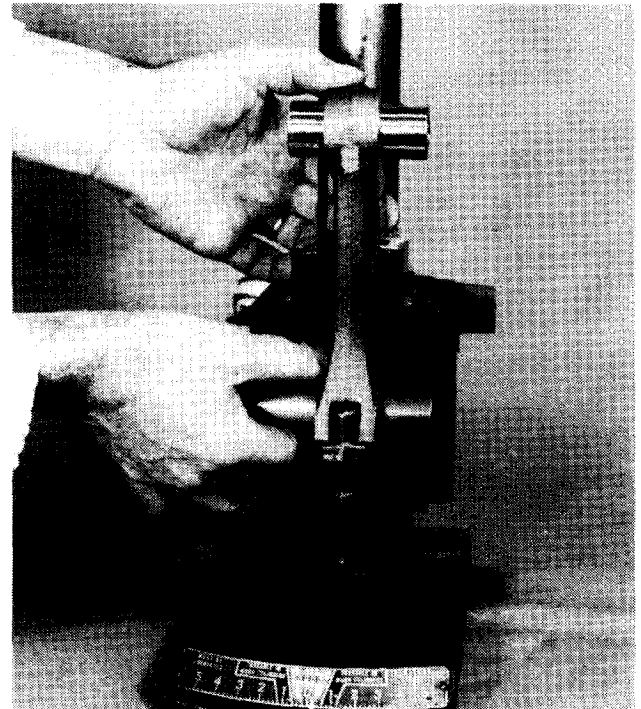

Checking Connecting Rod for Twist and Alignment

This may be checked on a fixture with the piston pin assembled in the rod before assembling the piston; but regardless of this preliminary check the completed piston and rod assembly must be rechecked and there must not be more

than 0.05mm (.002") twist or out of squareness checked over a spread of approximately 100mm (4"). If excessive, replace the rod.

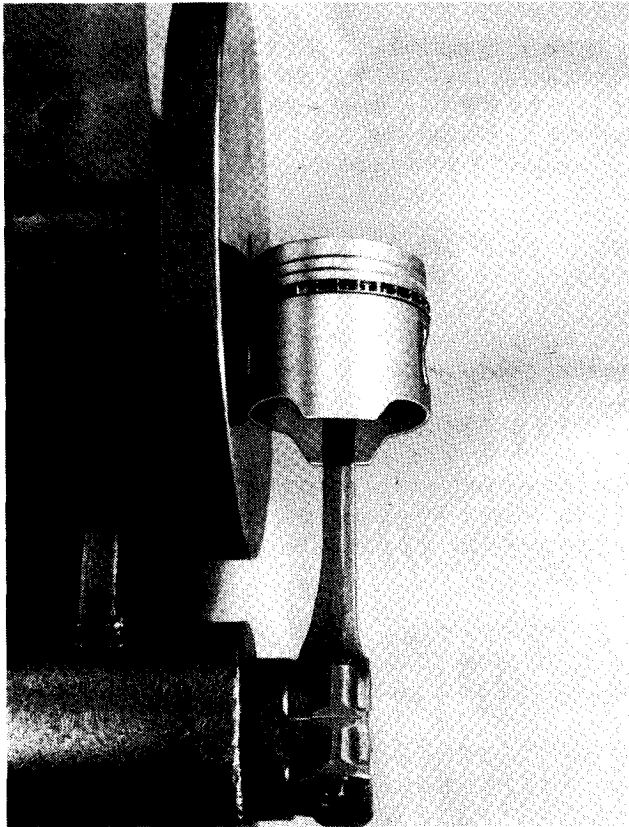

Checking Connecting Rod Assembly for Alignment

Pistons are cam and taper ground, and this must be taken into consideration when checking alignment of the assembly, since the diameter in line with the piston pin would be less at the top of the skirt than at the bottom.

## PISTON RINGS

Check the piston rings in the cylinder for gap.



Checking Ring Gap

To do this, insert a piston in the cylinder bore in an inverted position and then insert each ring one at a time about 50mm (2") down in the bore and bring the bottom edge of the piston up against the ring to square it up in the cylinder bore. If the ring does not have sufficient end gap clearance, file one end of the ring until sufficient clearance is obtained.

Check the gap between the ends of the ring with a feeler gauge in accordance with specifications shown in the Limits and Clearance chart.

Prior to installing the rings on the piston, check each ring in its respective groove to the limits specified in the manual. If ring to land clearance exceeds maximum serviceable limits, pistons must be replaced.



Checking Ring Clearance in Groove

## RECOMMENDED METHOD OF INSTALLING PISTON RINGS

1. Prior to ring assembly check the ring grooves for nicks and burrs. This is done by rotating each unassembled ring around its groove to be sure of free action.

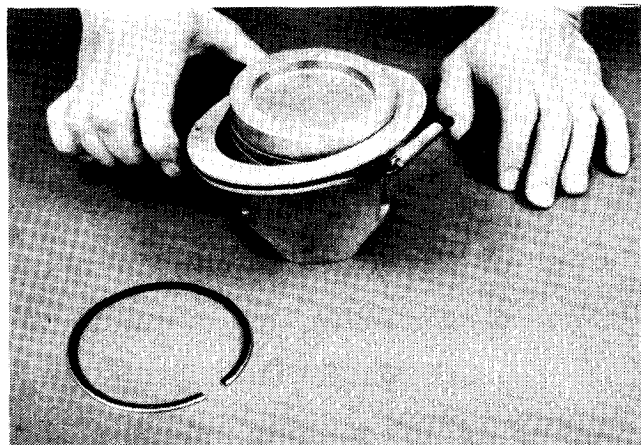

Installing Rings with Ring Expander Tool

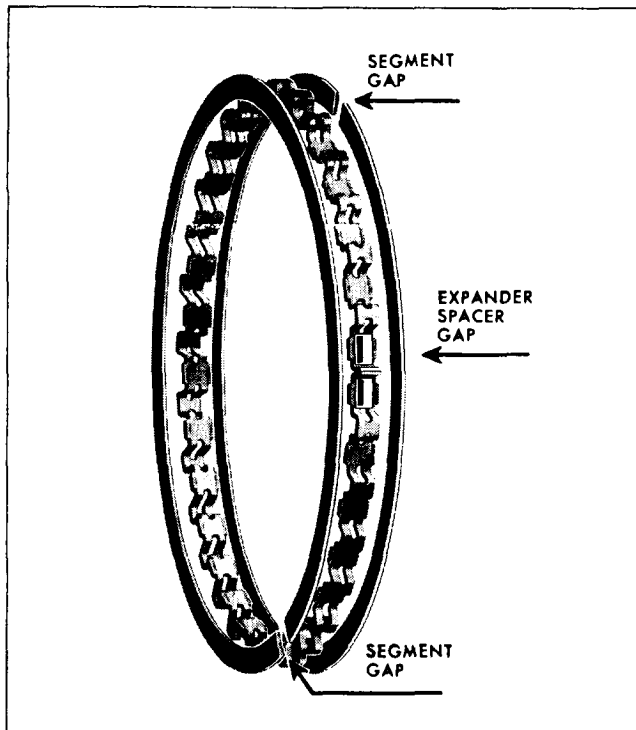

Three Piece Oil Ring

2. The 3 piece oil ring should be installed first on the piston, from the top side so skirt will not be scratched.

- a. Place stainless steel expander spacer in groove with ends butted.
- b. Install steel segment on top side of expander spacer with gap of segment approximately 90° beyond gap of stainless steel expander spacer, making certain that the expander spacer is still in a butted position.
- c. Install second segment on bottom side of the expander spacer with segment gap approximately 90° from the expander gap in opposite direction from which the top segment has been installed.
- d. Recheck assembly — rings should be free to move in the groove, however, a slight drag



Oil Piston and Rings

will be evident because of the side scaling action of the ring assembly. **BE SURE EXPANDER SPACER REMAINS IN BUTTED POSITION.**

3. To install the balance of the rings, use a ring tool with **recess** side up and place the ring in with the bottom side up. **Start with the lowest ring first.**

- a. Position ring in the tool so the expanding fingers will fully engage both ends.
- b. Apply pressure on handles so ring is completely expanded. Pass the expanded ring and tool **recessed side down** over the piston to the proper groove.

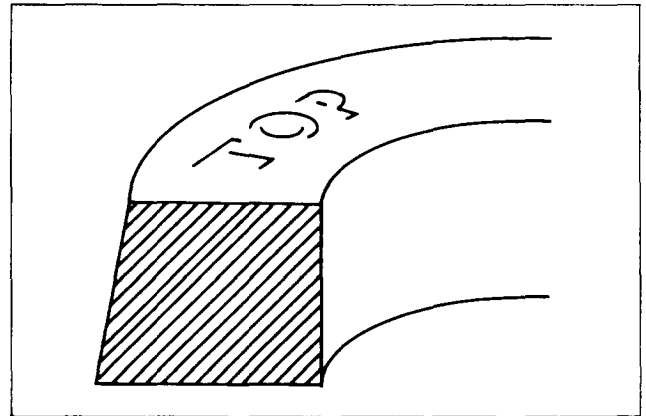

Install Tapered Rings with "Top" Side Up.

**CAUTION:** Some piston rings are taper faced. These are clearly marked "TOP" on the side to be up when assembled on piston, and some rings have the top side marked with a color band or a PIP mark.

4. When pistons are ready for installation in the cylinders, oil generously. Compress rings carefully using a good ring compressor and a light tap on the head of the piston will allow the assembly to go into the cylinder very easily. If any difficulty in tapping piston and ring assembly into the cylinder is encountered, the compressor should be removed and rings checked for correct installation in the groove.

**CAUTION:** The pistons have offset piston pins. Be sure to install pistons with notch in top toward the front of the engine and the numbered side of the connecting rod facing the camshaft.

## CRANKSHAFT AND MAIN BEARINGS

1. Using a puller, remove pulley from crankshaft.
2. Remove screws and remove gear cover.
3. Remove the crankshaft gear and keys.

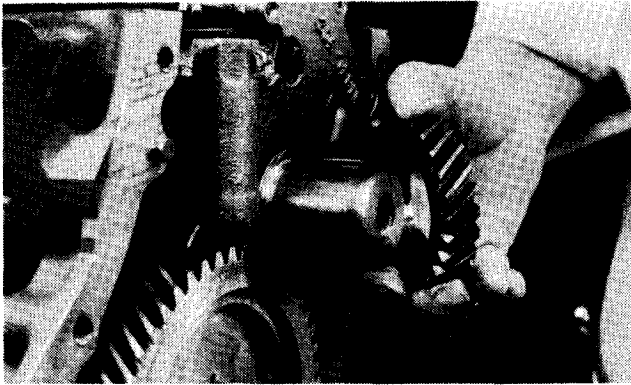

Removing Crank Gear

4. Using a puller, remove cam gear.

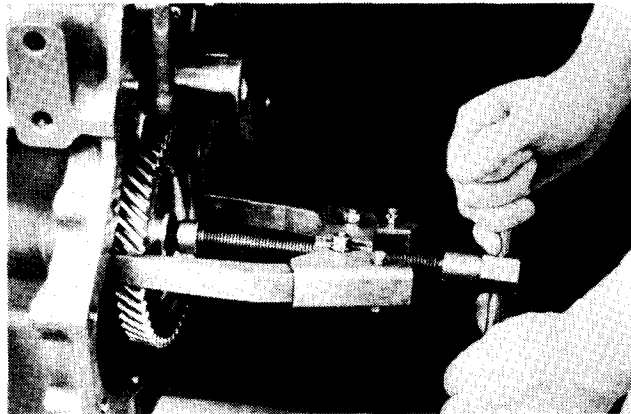

Removing Cam Gear with Puller

5. Remove the oil pump, by removing cap screws holding pump to front of the engine.

6. Remove each main bearing cap, one at a time, and inspect the bearing and crankshaft journals.

If there is any indication of flaking out, scoring or actual wear, — **they must be replaced.**

### BEARINGS

Tri-metal bearings when new are smooth and highly polished. However, *a very few hours of*

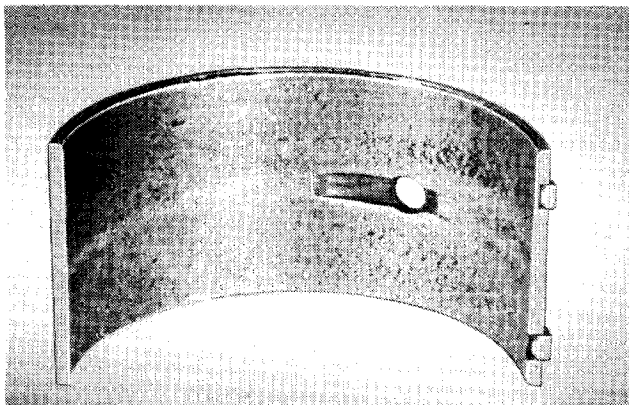

Appearance of a Good Bearing

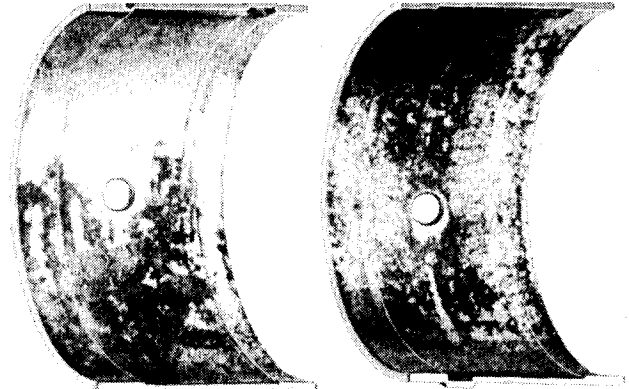

Bearing Damage Due to Corrosion

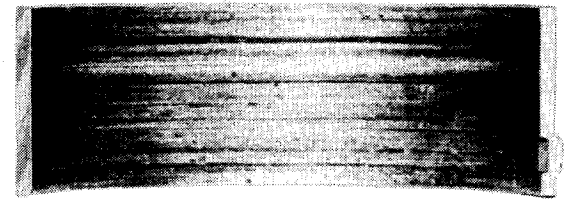
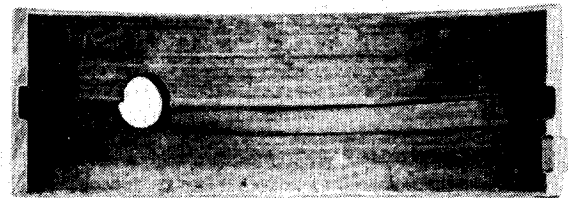

Scored Bearing Due to Dirt or Lack of Oil

*operation will change their appearance completely. The bearing surface becomes a leaden gray in color and develops minute craters, almost cellular in appearance as indicated in the photograph, which follow the pattern of the matrix. This appearance is a natural characteristic of this type bearing and in no way indicates failure.*

7. If the visual inspection appears satisfactory, they should be removed and checked for thickness using a ball micrometer.

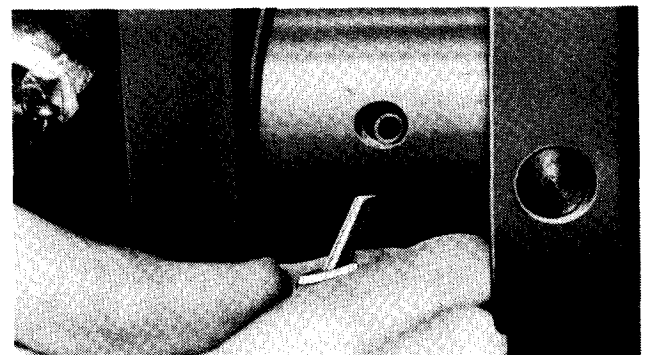

Removing Main Bearing

**CAUTION:** The upper main bearing shells are grooved. The lower main bearing shells, on some models, are not. The ungrooved bearing shell must be placed in the bearing cap, not in the block, or oil to the bearings will be cut off.

To remove the upper half of the bearing shell use a special tool obtainable at most parts houses, which is a pin and an angular head. It may be inserted in the oil hole of the crankshaft and as the crankshaft is turned in a clockwise direction, the head of this pin picks up the bearing shell and forces it out of the bore in the block.

The thickness of the bearing shells is given in the Limits and Clearance Chart, and if this



Measuring Bearing Thickness

thickness has been reduced more than 0.013mm (.0005") beyond the maximum allowable tolerance the bearing shell must be replaced.

8. If visual inspection of the crankshaft shows no indication of excessive wear or scoring, the clearance of the bearing should be checked.

9. Check each bearing, one at a time, by using a piece of Plastigage of a diameter specified to check certain clearances.

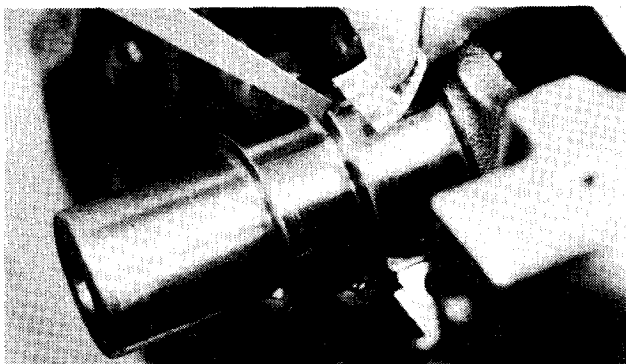

Checking Bearing Clearance with Plastigage

By placing the Plastigage on the crankshaft bearing surface and tightening the bearing and cap in place, the width of the Plastigage after crushing will determine the bearing clearance.

**CAUTION:** When using this method DO NOT TURN the crankshaft as that would destroy the Plastigage.

If crankshaft is scored, or worn enough so that new bearings will not fit with the required clearance, it should be removed and reground.

Standard crankshafts may be reground to decrease the diameter a maximum of 1.0mm (.040").

Before shaft is reground, it must be checked for straightness and straightened if necessary to be within 0.05mm (.002") indicator reading. When reground, the fillet radii must be within dimensional limits and must be perfectly blended into thrust and bearing surfaces. **The crankshaft must be nitempered after regrinding.**

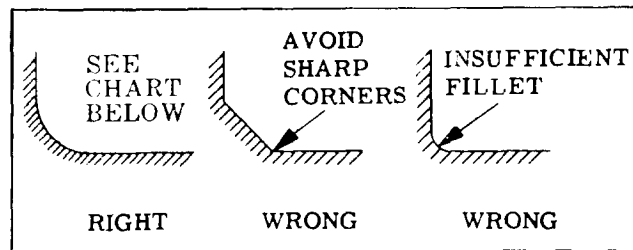

TM	2.8R (.11") on all crankpins 3.0R (.12") on all mains
----	----------------------------------------------------------

Crankshaft Fillet Radii

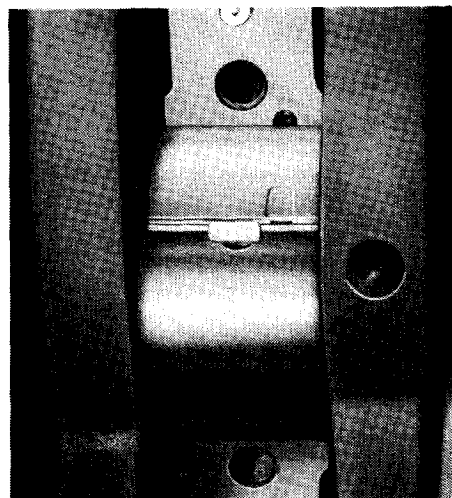

Replacing Bearing

## CAMSHAFT

1. Remove the screws holding the camshaft thrust plate to the front of the cylinder block, which makes it possible to pull the camshaft forward out of the bearings.

2. Before removing the camshaft completely, check the clearance of the bearing journals in the block. To do this use strips of feeler stock 6mm (1/4") wide with edges dressed with a stone to eliminate any burrs or feathered edges.

If clearance is equal to or greater than the amount indicated under wear limits, check the diameter of the camshaft journals to determine the next step. Excess wear at these positions require replacement of the shaft.

3. Tappets can then be lifted out and lined up in sequence, for installation in the same location unless inspection shows that they require replacement.

**CAUTION:** When installing camshaft use special care to prevent camshaft bumping and loosening expansion plug at rear of crankcase causing an oil leak.

## TAPPETS

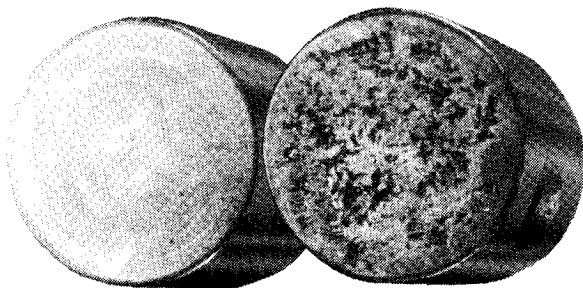

ACCEPTABLE

NOT ACCEPTABLE

Valve Tappet Wear Comparison

1. Inspect each tappet carefully. Two or three small pits on the contact face is acceptable; more than that calls for replacement of the tappet.

Oversize tappets are available as required.

2. Check the outside diameter with a micrometer to determine if replacement is necessary because of wear. Refer to limits and clearance section 12.

## REAR CRANKSHAFT OIL SEALS

The overhead valve engines have the rear crankshaft oil seals incorporated in the combination rear main bearing cap and filler block.

The newer type crankshaft oil seal has a stiffener ring imbedded in the rubber and no metal retainer is required.



Rear Main Bearing Cap and Filler Block

The overhead valve engines have a good, trouble-free rear crankshaft oil seal — if carefully installed.

**IMPORTANT:** Installing rear oil seals correctly demands careful workmanship. Install seal with lip pointing toward engine.

Worn oil seals should be replaced in the following manner:

1. Remove rear bearing cap and filler block assembly by using a puller as shown.

Remove old seals and thoroughly clean all contact surfaces.

2. Install crankshaft oil seals "A" — on engine block and main bearing cap.

Before installing — break edge "C" slightly on both cap and block to avoid cutting the seals during installation and coat seal edge "E", contacting the groove with sealing compound.

**NOTE:** This oil seal can be installed without removing the crankshaft — in this case, use only light grease in the seal groove to assist sliding the seal in place. Apply pressure to the seal so that it will hug the crankshaft which will also help moving it in place.

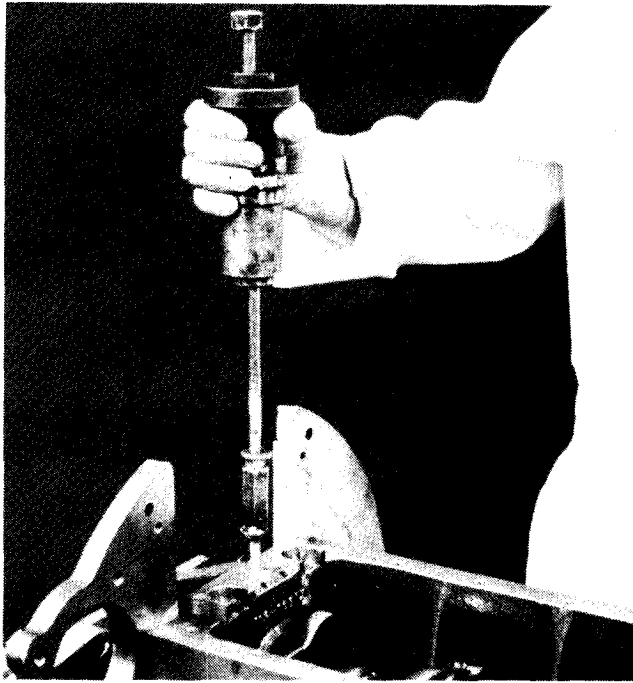

Removing Rear Oil Seal

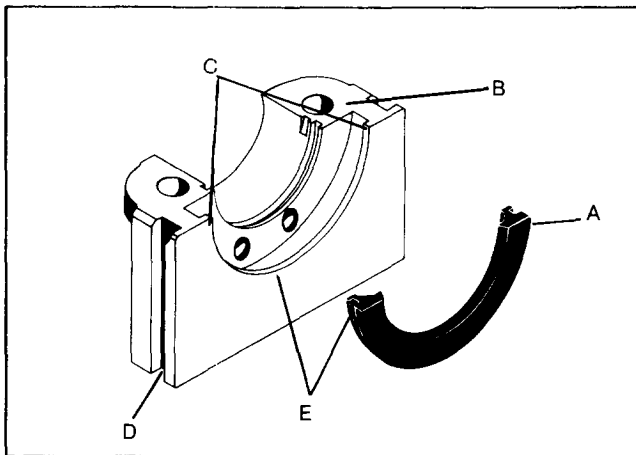

Filler Block and Seal



Crankshaft Oil Seal in Block

3. Apply a light coat of cement (national oil seal or EC-847) to the butting ends of the crankshaft oil seal halves. Allow to become tacky before assembling. Lightly coat the crankshaft contact edge of the seal with graphite grease to prevent damage prior to use.

4. Install Crankshaft.

5. Apply a light coating of RTV Gasket Material to surface "B" and graphite grease to the oil seal lip. Carefully install the combination rear bearing cap and filler block on to the dowels. Insert the capscrews and torque to 150-162 Nm (110-120 Lb. Ft.)

6. After the rear cap is in place and torqued, inject RTV into each side seal slot "D" as shown in illustration. Force the RTV into the channels until a steady flow comes out the corner chamfers.

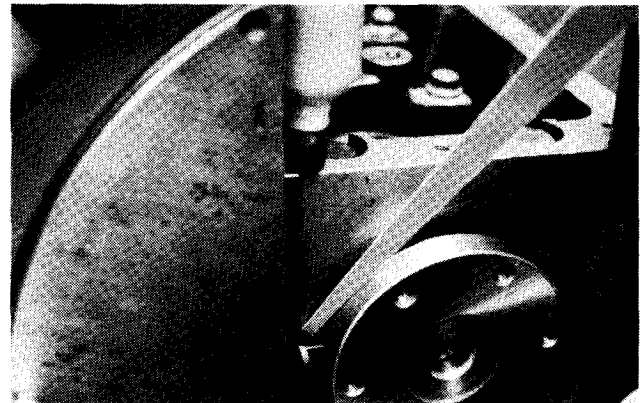

Installing RTV in Rear Filler Block

**NOTE:** Oil leakage will occur if any voids are left along these slots.

7. Dip the curing insert in clean water. Force the insert into the RTV filled channel until it is flush or slightly below the oil pan rail. This insert insures complete cure of the RTV.



Install Curing Insert



8. Prior to installing oil pan, apply a small bead of RTV material to the rear bearing cap and filler block as shown.

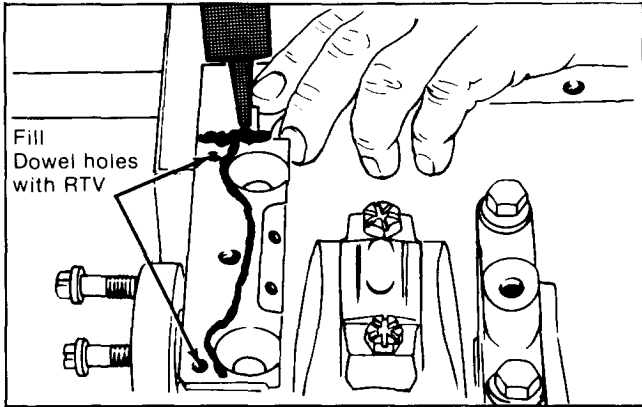

Applying RTV to Rear Bearing Cap and Filler Block

## OIL PUMP

The oil pump is assembled to the front of the cylinder block and front main bearing cap and is held in place by capscrews.

The extended portion of the body acts as a pilot, fitting closely in a counterbore in the block and bearing cap; maintaining a definite relationship between the crankshaft and the oil pump assembly.

The pump is driven by a hardened key mounted in the crankshaft.

**NOTE:** Later model oil pumps do not have an extended nose for piloting to the crankcase. Tool #T-1044 should be mounted on the crankshaft nose while installing this type of oil pump. Remove tool after tightening oil pump mounting screws to torque specification.

If tool is not available, install pump against cylinder block and snug up screws by hand. Rotate the crankshaft two or three times, then tighten the screws to torque specification. Rotate the crank to be sure the pump does not bind.

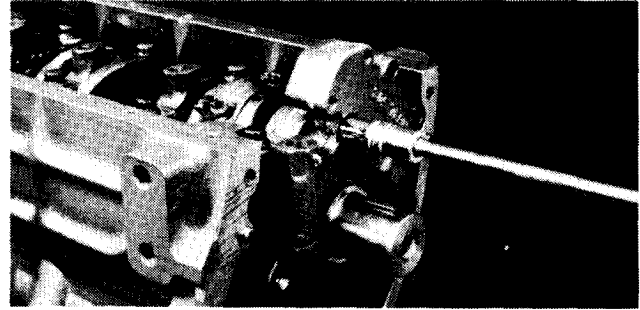

Oil Pump Removal

When the pump is removed and disassembled, examine the impellers, cover and cavity for wear; inspecting the key and keyway at the same time. If scored or worn badly they must be replaced.

Examine the pick-up screen for clogging or damage.

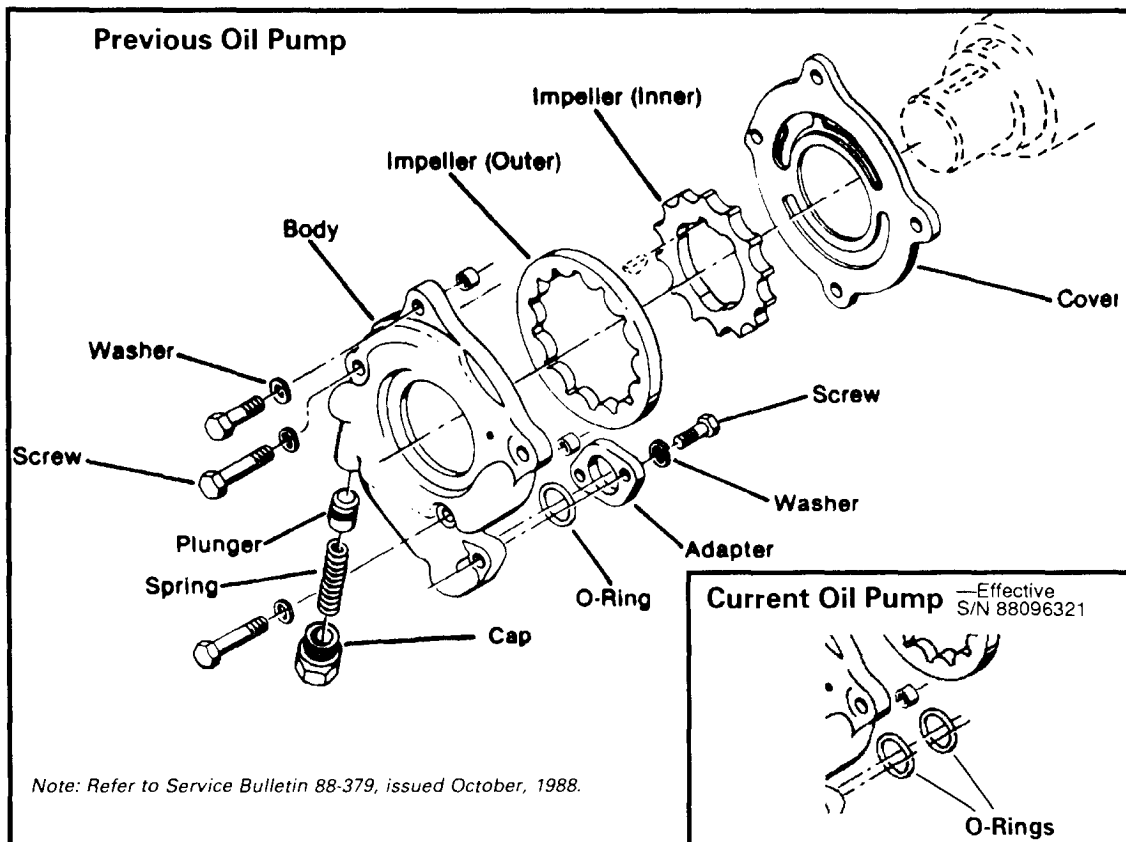

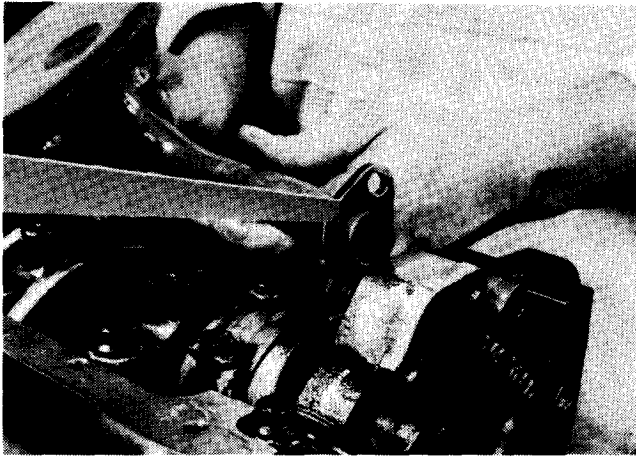

O-ring at pump inlet.

Examine the O-Ring at the pump inlet. If damaged, replace.

Engine oil pressure must be maintained to specification for satisfactory engine life.

The oil pump must be fully seated in the counterbore. No gaskets are used in this assembly (see note for later model oil pumps).

Install mounting capscrews and tighten to 20-24 Nm (15-18 Lb. Ft.)

### TIMING GEARS

Please reference SPB 83-340.

1. Timing gears should be inspected for excessive wear and/or pitting and replaced if necessary.

2. Examine the camshaft thrust plate carefully for scoring and wear and if any indication of either shows, a new thrust plate should be assembled.

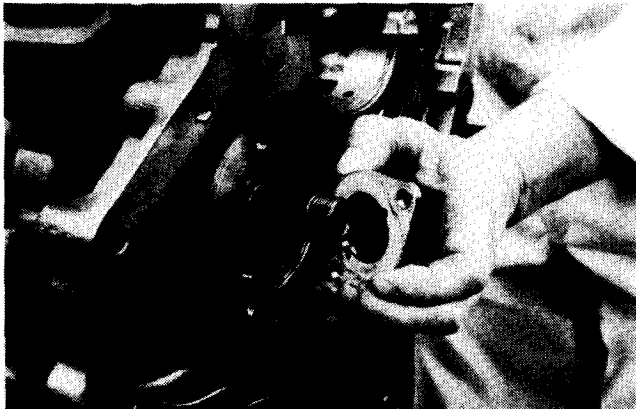

Camshaft Thrust Plate

3. Assemble the cam gear to the camshaft by driving or pressing it on, at the same time holding the camshaft forward with a suitable bar through the fuel pump opening in the block so there is no possibility of the camshaft bumping the expan-

sion plug at the rear end and forcing it out of position, thus causing an oil leak.

**CAUTION: NEVER USE THE CAMSHAFT NUT TO PRESS THE GEAR ONTO THE CAMSHAFT.** This will break the threaded end off cast iron camshafts.

Assemble camshaft nut and torque to specifications shown in section 11. Do not use impact wrench or over torque cam nut.

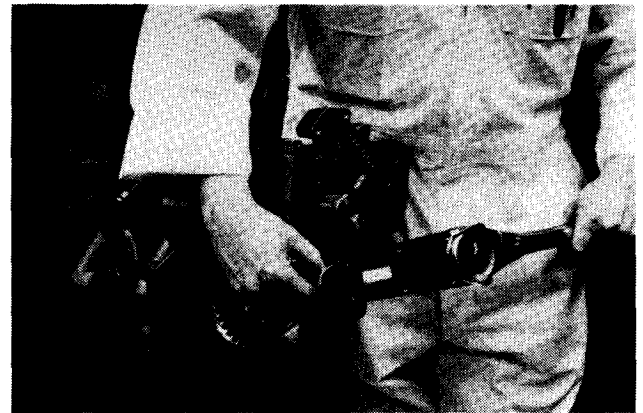

Torquing Cam Gear Nut

Check camshaft end play as shown in illustration. Refer to limits and clearance section for correct dimension.

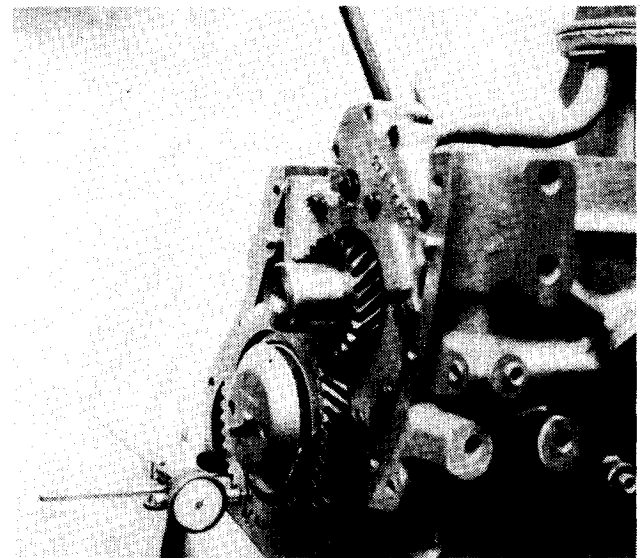

Checking Camshaft End Play

4. Drive the crank gear on the shaft making sure that the marked teeth on the cam gear straddle the marked tooth on the crank gear, which assures you of the crankshaft and camshaft being in time.

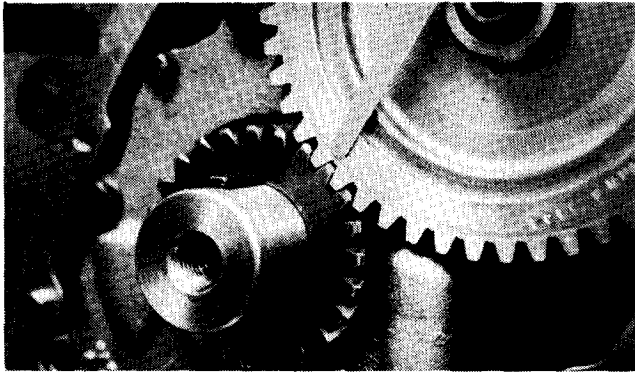

Timing Gears Assembled According to Timing Marks

## CRANKSHAFT END PLAY

The crankshaft end play is controlled by the center flanged bearing. No shims are required. If end play exceeds 0.18mm (.007") using a feeler gauge, replace the flanged bearing. End play should be between the 0.17mm (.0067") and 0.04mm (.0015") limits.

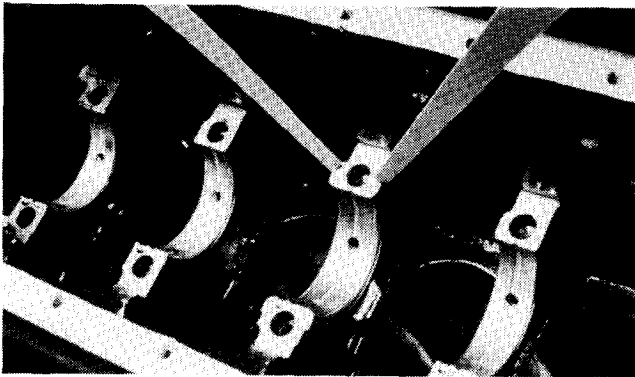

Flanged Bearing Controls Crankshaft End Play

## FLYWHEEL AND FLYWHEEL HOUSING

**NOTE:** On early models, special capscrews having sealing bands are used in the upper holes to mount the flywheel housing to the cylinder block. These special capscrews must be used to prevent oil leakage.

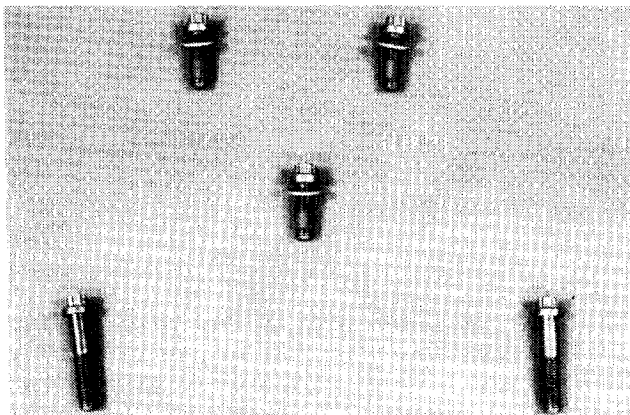

Special Capscrews

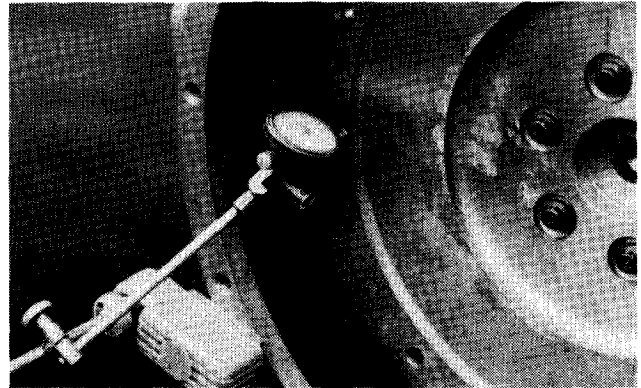

Checking Flywheel Run-Out

The flywheel is machined and balanced so that the clutch face and locating counterbore will run true with its axis.

To be sure that the crankshaft flange has not been sprung or otherwise damaged or that the counterbore in the flywheel, which locates it on the crankshaft, is not damaged, mount an indicator on the flywheel housing and check the flywheel for runout. Caution: When checking runout remove spark plugs to allow engine to be turned over freely.

The indicator should be set up so that it contacts the clutch face or the vertical surface of the clutch counterbore, then turn the flywheel at least one full revolution at the same time holding against the crankshaft to offset the possibility of end play.

Excessive runout of the flywheel, in either position, is probably caused by dirt in or damage to counterbore locating the flywheel on the crankshaft flange.

Re-locate the indicator to check the inside diameter of the counterbore. In both cases the maximum indicator reading must not be more than 0.20mm (.008").

When assembled, mount the indicator on the flywheel so that it contacts the housing face and turn the crankshaft, at the same time holding against it to counteract end play. The maximum indicator reading must not exceed 0.20mm (.008").

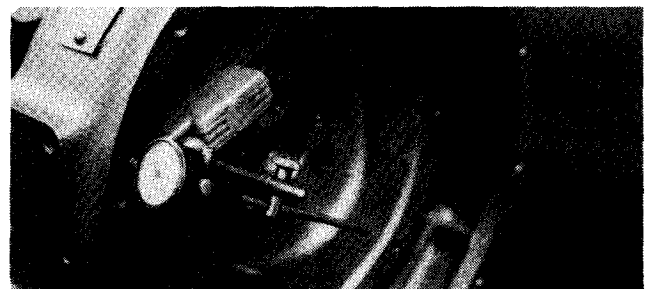

Checking flywheel Housing Face

Re-locate the indicator to contact the housing bore and check this in the same manner. The same runout limits prevail.

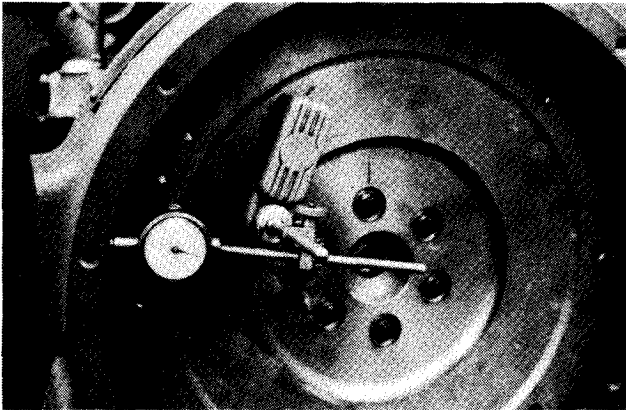

Checking Housing Bore

## REASSEMBLING ENGINE

In the foregoing, we have outlined procedures for checking, repairing or replacing the many wearing parts in the engine.

In most cases, the instructions have covered the reassembly of parts or subassemblies made up of several parts.

When reassembling pistons and connecting rods, use a good ring compressor and oil the bores thoroughly. A hammer handle may be used to bump the pistons out of the ring compressor into the cylinder bore.

**NOTE:** The pistons have offset piston pins. Be sure to install pistons with notch in top toward the front of the engine and the numbered side of the connecting rod facing the camshaft, as indicated in the photograph below.



Once more, we call attention to care demanded to prevent connecting rods damaging the cylinder bore finish and at the same time as they are assembled over the crank pin, locate them carefully in order to protect the bearing surfaces.

Always lubricate the bearings with clean engine oil when assembling, and tighten them to the torque specified.

## INSTALLING HEAD

1. Make sure that gasket contact surfaces on the head and block are clean, smooth and flat. Check flatness with straight edge and feeler gauge in three positions lengthwise and five crosswise. The maximum permissible is 0.10mm (.004") low in the center lengthwise, gradually decreasing towards the ends, or 0.076mm (.003") crosswise or in localized low spots. If these limits are exceeded, replace the cylinder head.



Checking Cylinder Head Flatness Lengthwise

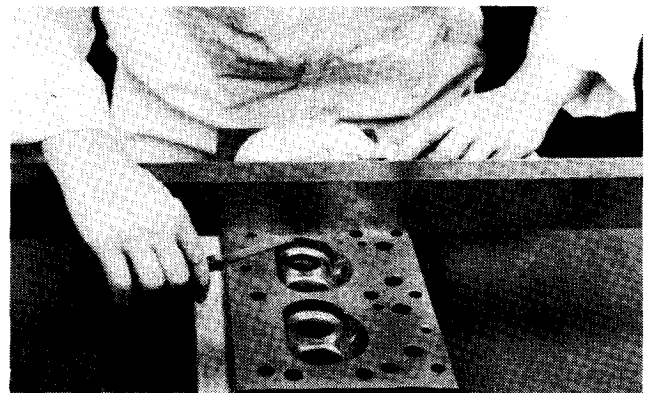

Checking Cylinder Head Flatness Crosswise

2. Use new cylinder head gasket, which is precoated, thus no cement is required.

3. Before installing head cap screws in the block, be sure the threads in the block and on the cap screws have been properly cleaned. Should these tapped holes need cleaning or reconditioning, care should be taken to use the proper tap.

Tap: M10 x 1.5 CLASS 6G  
M12 x 1.75 CLASS 6G

4. Using a chain hoist, lower the cylinder head assembly evenly over the locator stud. Replace

the locator stud with the proper cylinder head capscrew.

5. The cylinder head capscrews require no sealant but should be installed with a light coating of engine oil or lubriplate to reduce friction and insure proper clamp load and head capscrew torque. See torque chart on page 72 for proper torque and sequence.

**Please reference SPB 90-391.**

**CAUTION:** No substitution of cap screws should be made as these materials are heat-treated. Use only genuine Continental parts.

6. Install the spark plugs at this point. Having the plugs in now, eliminates the risk of dirt and foreign objects falling into the cylinder.

### INSTALLING OIL PAN

Before assembling the oil pan make sure the contact surfaces are flat and clean of any gasket material or oil.

A form-in-place gasket material is used for sealing the engine oil pan to the crankcase. The form

-in-place gasket should be applied to the oil pan and filler blocks as shown here.

Tighten the screws in accordance with limits prescribed in the torque chart—to avoid looseness or overstressing.

When engine is completely assembled and filled with proper oil, (See Lubrication Sec.) set tappets according to the following chart:

MODEL	INTAKE	EXHAUST
TM	0.36mm (.014")	0.46mm (.018")



Setting Tappets

**NOTES:**

1. Parts must be assembled within 20 minutes after applying gasket material.
2. Caution must be used in handling the gasket materials. Read Labels.

2.0mm (.080) dia. bead of Form-in-Place gasket material applied to oil pan and filler block as shown

This area of Form-in-Place gasket must intersect vertical cavities both sides

Top View  
Crankcase contact face

Rear Bearing Cap and Filler Block

(See notes 1 and 2)  
Form-in-Place gasket material to plug holes.  
Min 6.0mm (.236) deep from contact surface.

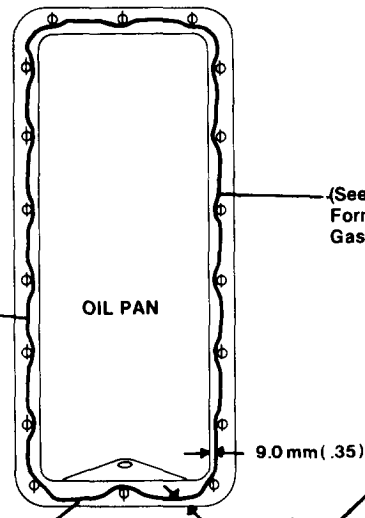

(See Notes 1 and 2)  
Form-in-Place  
Gasket

(See Notes 1 and 2) Form-in-Place gasket material must extend from side seal recess to inner edge of seal retainer as shown, both sides.

**IMPORTANT** - After assembly of the bearing cap to the crankcase, fill bearing cap side slots to capacity using RTV and syringe furnished in kit. Sealant must bleed out chamfer at crankcase split line.

The two curing inserts (pipe cleaners) included in the kit must be used as follows: Dip the curing insert into a container of clean water and insert full length into bearing cap side slot cavities filled with RTV material, making certain the insert is centrally located in side slot. Install curing insert until approximately 5/8" protrudes from slot. Cut off flush with pan rail.

Bottom View  
Oil Pan Contact Face

Typical RTV Oil Pan Application for the Overhead Valve Engine.

# Section 10 - Trouble Shooting

## **WARNING**

Bodily injury or death may result to individuals during operation of an engine within any enclosure not adequately or properly ventilated. Engine operation in any enclosure requires adequate and proper ventilation to avoid asphyxiation or other interruption of normal breathing, to supply sufficient air to cool the engine, provide air to mix with fuel and to carry away heated air from the building.

Read and observe safety warnings on pages 1 and 2.

A preventive maintenance system including inspection, lubrication and adjustment as recommended in our Maintenance Section will prevent the greater portion of gasoline engine troubles.

Failure of a gasoline engine to start is mainly due to two things: ignition trouble or failure in the fuel system.

Operators handling the same engine every day, soon develop a sense of impending trouble when abnormal operation occurs. Immediate attention to these danger signals can prevent major failures, insure dependable operation and increase the life of the engine.

Operators should depend on their well-developed senses of **feeling, hearing, seeing** and **smelling** and replace their sense of taste in this type of work — **with a generous amount of "Common Sense"**.

A good rule to follow in locating trouble is to never make more than **one** adjustment at a time — then locate the trouble by a process of elimination. Remember the cause is usually **Simple** — rather than mysterious and complicated.

Following are listed some of the normal complaints encountered in routine operation of all gasoline engines and the probable causes.

### **A — STARTING MOTOR — WILL NOT CRANK ENGINE**

- 1 — Weak or dead battery.
- 2 — Poor ground connection.
- 3 — Faulty starting switch or relay.
- 4 — Defective starting motor.

5 — Internal engine seizure — turn engine manually to determine cause.

### **B — ENGINE CRANKS — BUT DOES NOT START:**

Disconnect one spark plug wire, turn ignition on with starter cranking engine and free end of wire 3mm (1/8") from cylinder head — note spark.

## **WARNING**

Do not hold ignition wires with bare hands since shocks or other injuries can result. Sparks or flames near a battery could cause an explosion or fire. Battery acid can cause corrosive burns. Always wear eye protection. Use of jumper cables or battery charging should be done only as directed by manufacturers safety instructions.

Read and observe safety warnings on pages 1 and 2.

### **1 — NO SPARK:**

(A) — **If Ammeter Shows No Discharge** — it indicates an open primary circuit due to:

- 1 — Open primary wires.
- 2 — Defective ignition switch.
- 3 — Faulty coil.

(B) — **Normal Ammeter Reading** (Discharge 2-5 amps) — this indicates that the primary circuit is OK — trouble may be in secondary circuit due to:

- 1 — Broken or grounded high tension wire from coil to distributor.
- 2 — Wet high tension wires.
- 3 — Faulty distributor cap or rotor.
- 4 — Broken secondary winding of coil.

(C) — **Excessive Ammeter Reading** (Discharge over 5 amps) — indicates a "short" in the primary winding which may be due to:

- 1 — Shorted or grounded primary winding.

### **2 — WEAK SPARK** — may be caused by:

- (A) Loose ignition wiring connections.
- (B) Wet spark plug wires.
- (C) Cracked distributor cap.
- (D) Weak ignition coil.

**3 — GOOD SPARK AT EACH PLUG** — indicates that ignition system is OK and trouble is in fuel

system — which may be due to:

(A) **No Gas in Carburetor** — which may be due to:

- 1 — No gas in tank.
- 2 — Clogged filter or lines.
- 3 — Faulty fuel pump.
- 4 — Leaky fuel line from tank.
- 5 — Plugged vent in fuel tank cap.

(B) **Gas in Carburetor** — which may be flooded due to:

- 1 — Too much choking — plugs are wet.
- 2 — Wrong float level.
- 3 — Choke not operating correctly.
- 4 — Water in Gas.

### **C — ENGINE RUNS WITH CONTINUOUS MIS-FIRING:** Due to:

- 1 — Uneven compression.
- 2 — Wet or deteriorated high tension wires.
- 3 — Cracked distributor cap.
- 4 — Faulty spark plugs—if spark plug porcelain is white when removed, use **Colder** plug — if light brown OK — if Black or oily use **Hotter** plug.

### **D — ENGINE RUNS UNEVENLY**

1 — **At Idling Speed** — which may be due to:

- (A) Too wide spark plug gaps.
- (B) Poor Carburetor idle adjustment.
- (C) Wrong float level.
- (D) Carburetor or intake manifold air leaks.
- (E) Leaky cylinder head gasket.

2 — **At High Speed** - which may be due to:

- (A) Weak valve springs.
- (B) Spark plug of wrong type or incorrect gap.

### **E — ENGINE RUNS IMPROPERLY**

1 — **Back-Firing into Manifold** — indicates **Too Rich** a fuel mixture; into carburetor indicates **Too Lean** a mixture—may be due to:

- (A) Late Ignition Timing.
- (B) Clogged Air Cleaner.
- (C) Fuel line restrictions.
- (D) Clogged carburetor jets.
- (E) Sticking Valves.
- (F) Weak or broken valve springs.

2 — **Excessive Ping (Detonation)**—results in damaged pistons and bearings and is caused by pre-ignition or using inferior grade of gas.

3 — **Engine Idles Too Fast** — indicates improper throttle adjustment or weak throttle return springs.

4 — **Engine Dies When Idling** — which indicates incorrect speed or mixture adjustment; clogged idling circuit in carburetor or wrong choke adjustment, or air leaks in intake manifold.

5 — **Engine “Stumbles” on Acceleration** — which may be due to defective accelerator pump or air in fuel lines.

6 — **Defective Spark Plugs.**

F — **LACK OF POWER** — which may be due to:

- 1 — Poor Compression.
- 2 — Wrong Timing.
- 3 — Throttle control not opening fully.
- 4 — Air leak in fuel system.
- 5 — Restriction in air cleaner — should have vacuum less than 250mm (10”) water.
- 6 — Exhaust line obstructed - should have back pressure of not more than 500mm (20”) water.
- 7 — Poor fuel.
- 8 — Piston rings sticking or worn.

G — **POOR COMPRESSION** — check with compression gauge — if irregular, seal the piston with a teaspoonful of engine oil poured through the spark plug hole, and take a second reading; if pressure does not increase this will indicate that poor seating of valves are at fault.

Poor compression may be due to:

- 1 — Valves holding open — no tappet clearance.
- 2 — Leaky cylinder head gasket.
- 3 — Broken or weak valve springs.
- 4 — Burned or sticking valves.
- 5 — Badly worn, broken or stuck piston rings.
- 6 — Wrong valve timing.
- 7 — Bent push rods.

### **H — OVERHEATING**

- 1 — Lack of water in radiator.
- 2 — Fan belts slipping.
- 3 — Thermostat sticking or inoperative.
- 4 — Radiator clogged or leaky.
- 5 — Late ignition timing.
- 6 — Back pressure in exhaust line.
- 7 — Defective water pump.
- 8 — Overloading of engine.

### **I — LOW OIL PRESSURE**

- 1 — Low Oil level.
- 2 — Oil pressure gauge or line faulty.
- 3 — Oil too light — diluted.
- 4 — Suction screen plugged.
- 5 — Dirt in relief valve or broken spring.
- 6 — Worn bearings.
- 7 — Worn or damaged oil pump impeller.
- 8 — Worn Cam Bores or Journals.

J — **HIGH OIL PRESSURE**—should not exceed recommended pressures except when engine is starting up cold. Abnormally high oil pressure is not desirable because it increases oil consumption — possible causes of high oil pressures are:

- 1 — Engine oil too heavy.
- 2 — Stuck relief valve.

- 3 — Obstruction in distributing line.
- 4 — Faulty oil pressure gauge.

**K — HIGH OIL CONSUMPTION**

- 1 — Oil leaks.
  - 2 — Too high oil level.
  - 3 — Incorrect grade of oil used.
  - 4 — Clogged crankcase breather.
  - 5 — Oil pressure too high — stuck relief valve.
  - 6 — Piston rings not run-in, due to too smooth cylinder bore finish or glazed condition.
  - 7 — Worn, broken or stuck piston rings and clogged oil control rings.
  - 8 — Worn pistons and bores.
  - 9 — Worn bearings.
  - 10 — Worn valve guides.
- (Manifold may be removed for visual inspection.)

**L — ENGINE KNOCKS AND OTHER NOISES**

- 1 — **Operating Knocks** — which may be due to:
  - (A) **Pre-Ignition** — Most common cause is due to wrong type plugs which are too hot.
  - (B) **Carbon** — noticeable when engine is accelerated while hot — clean head and pistons.
  - (C) **Timing** — early timing causes knocks similar to carbon — but may tend to kick back when starting.
  - (D) **Fuel** — detonation knock caused by poor gas.
  - (E) **Overloads** — particularly at lower operating speeds.
- 2 — **Mechanical Knocks**—result from wear, abuse or improper adjustments — which may be due to:
  - (A) **Crankshaft and Main Bearings:**
    - (1) **Worn or burned-out Main Bearings** — A heavy, dull knock when accelerating under load. Locate by shorting out plugs on both sides of the bad bearing.
    - (2) **Crankshaft End-Play** — excessive end-play is indicated by an intermittent knock which will come and go when the load is released and engaged.
  - (B) **Connecting Rod Bearings**
    - (1) **Worn or Burned-out Bearings** — The worst condition, a light pound or metallic knock, is noted at idling and to about 2/3 maximum

speed. Bad bearings can be determined by shorting out plugs.

**(C) Pistons and Wrist-Pins**

- (1) **Loose Wrist Pins** — noise doubles when the correct plug is shorted out — most noticeable at idling speed.
- (2) **Piston Loose in Cylinder** — “Piston-Slap” is noted by metallic knocking at low speed under load: but disappears at high speed — also most noticeable when starting cold—test by shorting out plugs.

**(D) Broken Piston Ring or Pin** — Sharp clicking noise that won’t short out.

**(E) Valves**

- (1) **Burned Valves and Seats or Bent Push Rods** — engine misses, especially at low speeds, or acceleration under load.
- (2) **Weak or Broken Valve Springs** — missing at low or high speeds when under load.
- (3) **Sticking Valves** — loss of power and popping sound when bad.
- (4) **Tappet noise** — excessive clearances cause noise when cold — which diminishes at normal operating temperature.
- (5) **Bent Push Rods** — engine misses at all speeds and loads — excessive tappet noise.

**(F) Camshaft** — Noise due to loose journals or end play — usually occurs at half engine speed.

**(G) Timing Gear Noise** — Loose or worn gears rattle or knock — tight gears hum.

**3 — Vibration Originating at Engine** — The most common sources of vibration originating in or on the engine, as distinguished from causes created outside the engine are as follows:

- (A) Misfiring
- (B) Misalignment of engine.
- (C) Bent or off-center coupling.
- (D) Engine loose on bed and type of mountings
- (E) Out of balance condition of flywheel and clutch assembly.

**NOTES**

---



---



---



---



---



---





# Section 11 - Torque Specifications

**NOTE:** The Following Torque Values are based on Phosphate Coated Fasteners (Class 10.9 & 12.9) and Black Oxide Coated Fasteners (Class 8.8 & 9.8).

## CYLINDER HEAD

ENGINE SERIES	SEE CHART
TM	Page 72

ITEM	THD SIZE	MAT'L CLASS	TORQUE	
			N-m	LB. FT.
Connecting Rods CAUTION: High limit is maximum. DO NOT Torque beyond high limit.	3/8	SAE GR 8	61-68	45-50
Main Bearing Caps	M14	12.9	150-162	110-120
Flywheels	M10	12.9	68-75	50-55
Flywheel Housings	M10	12.9	61-68	45-50
Rear End Plates				
Manifolds	M8	8.8/9.8	20-24	15-18
(Seezpruf)	M10	8.8/9.8	34-40	25-30
Gear Covers	M10	8.8/9.8	34-40	25-30
Water Pumps				
Oil Pans (Sheet Steel)	M8	9.8	14-19	10-14
Oil Pump	M8	8.8/9.8	20-24	15-18
Rocker Shaft Supports	M8	8.8/9.8	23-27	17-20
Accessories And Misc. Brackets	M6	8.8/9.8	8-11	6-8
	M8	8.8/9.8	20-24	15-18
	M10	8.8/9.8	34-40	25-30
	M12	8.8/9.8	75-81	55-60
	M14	8.8/9.8	122-135	90-100
	M16	8.8/9.8	190-203	140-150
Spark Plugs	M14		38-41	28-30
Camshaft Nuts	7/8		88-95	65-70
Crankshaft Pulley	M16	8.8	163-176	120-130
Rocker Cover	M8	9.8	7-8	5-6

**NOTE:** The Following Torque Values are to be used only if Torque Value for specific part to be installed is not listed on preceding sheets.

THD SIZE	TORQUE (Phosphate Coated Fasteners)					
	Class 8.8		Class 9.8		Class 10.9	
	N-m	LB.FT.	N-m	LB.FT.	N-m	LB.FT.
M6	8-11	6-8	8-11	6-8		
M8	20-24	15-18	20-24	15-18		
M10	34-40	25-30	34-40	25-30		
M12	75-81	55-60	75-81	55-60		
M14	122-135	90-100	122-135	90-100		
M16	190-203	140-150	190-203	140-150		
M20						

### PROPERTY CLASS MARKING

#### BOLTS AND SCREWS:

The property class symbols for metric bolts and screws are given in table at right. Marking shall be located on the top of the head. Alternatively, the marking may be indented on the side of the head for hex head products.

#### STUDS:

All metric studs used are of property class 10.9. If marked, marking will be at nut end.

PROPERTY CLASS	IDENTIFICATION SYMBOL	
	BOLTS, SCREWS AND STUDS	STUDS SMALLER THAN M12
8.8	8.8	○
9.8	9.8	+
10.9	10.9	□
12.9	12.9	△

### CYLINDER HEAD

#### TORQUE SEQUENCE

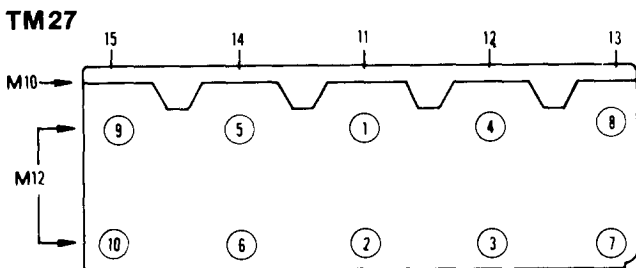
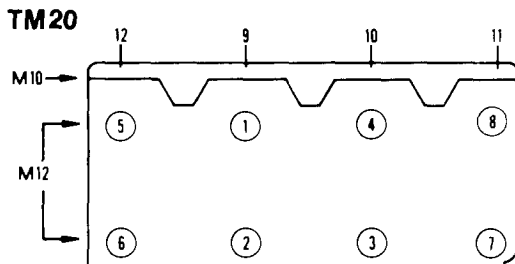
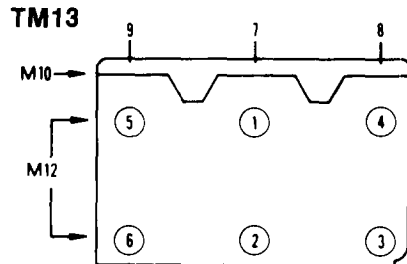

#### Cold Torquing Procedure

Step 1. Torque with Hand Torque Wrench to:

Screw Size	Ft.Lbs.	N-m
(SH) M12	30-35	41-47
(HH) M10	10-15	14-20
(HH) M12	25-30	34-41

Step 2. Torque with Hand Torque Wrench to:

Screw Size	Ft.Lbs.	N-m
(SH) M12	60-65	81-88
(HH) M10	20-25	27-34
(HH) M12	55-60	75-81

Step 3. Torque with Hand Torque Wrench in one single smooth motion:

Screw Size	Ft.Lbs.	N-m
(SH) M12	95-100	129-136
(HH) M10	35-40	47-54
(HH) M12	90-95	122-129

#### Hot Retorquing Procedure

Step 4. Retorque with Hand Torque Wrench (after engine reaches normal operating temperature) to the following values, in one single smooth motion:

Screw Size	Ft.Lbs.	N-m
(SH) M12	85-90	115-122
(HH) M10	30-35	41-47
(HH) M12	80-85	108-115

NOTE: (SH) = Socket Head Cap Screw (HH) = Hex Head Cap Screw



Torque all cylinder head capscrews using the proper torquing sequence shown here.

# Section 12 - Limits and Clearance Data

NOTE: Dimensions shown are for standard engines.

ENGINE MODEL	METRIC	TM (ENGLISH)
<b>VALVE GUIDE</b> (Intake & Exhaust)		
Length	60.4	(2 3/8)
Outside Dia.	16.700/16.675	(.6575/.6565)
Stem Hole Dia.	8.717/8.692	(.3432/.3422)
*Wear Limits—Max. Dia.	8.775	(.3447)
<b>VALVES, INTAKE</b>		
Stem Dia.	8.660/8.635	(.3409/.3400)
*Wear Limits—Min. Dia.	8.585	(.3380)
Seat Angle	29°45'	(29°45')
Stem Clearance Limits	0.082/0.032	(.0032/.0012)
*Wear Limits—Max. Cl.	0.132	(.0052)
Desired Stem Clear.	0.056	(.0022)
<b>VALVES, EXHAUST</b>		
Stem Dia.	8.640/8.615	(.3402/.3392)
*Wear Limits—Min. Dia.	8.565	(.3372)
Seat Angle	44°45'	(44°45')
Stem Clearance—Limits	0.102/0.052	(.0040/.0020)
*Wear Limits—Max. Cl.	0.152	(.0060)
Desired Stem Clear.	0.076	(.0030)
<b>VALVE SPRINGS</b>		
Outside Dia.	34.85	(1.372)
Length—Valve Closed	42.0	(1.6535)
Load—Valve Closed	24KgF	(52.8#)
*Wear Limits—Min. Wgt.	21.5KgF	(47.3#)
Length—Valve open	32.88	(1.294)
Load—Valve open	47.54KgF	(104.6#)
*Wear Limits—Min. Wgt.	42.5KgF	(93.5#)

ENGINE MODEL	METRIC	TM (ENGLISH)
<b>CAMSHAFT</b>		
Brg. Journal Dia. #1	47.511/47.486	(1.8705/1.8695)
#2	44.336/44.311	(1.7455/1.7445)
#3	42.749/42.723	(1.6830/1.6820)
*Wear Limits—Min. Dia.	0.025 (.001) Under Minimum New Shaft Diameter	
Bore—Inside Dia. #1	47.625/47.600	(1.8750/1.8740)
#2	44.450/44.425	(1.7500/1.7490)
#3	42.862/42.837	(1.6875/1.6865)
Bore—Clearance Limits	0.139/0.089	(.0055/.0035)
End Play	0.038/0.178	(.0015/.0070)
<b>CONNECTING RODS</b>		
Bush. Hole Dia.	30.175/30.150	(1.1880/1.1870)
Brg. Hole Dia.	52.375/52.362	(2.0620/2.0615)
Brg. Thickness	1.567/1.554	(.0617/.0612)
*Wear Limits—Min. Thk.	1.542	(.0607)
Dia.—Crank Pin	49.212/49.187	(1.9375/1.9365)
*Wear Limits—Min. Dia.	49.162	(1.9355)
Clearance Limits	0.080/0.016	(.0031/.0006)
Desired Clearance	0.048	(.0019)
*Wear Limits—Max. Cl.	0.091	(.0036)
Side Play	0.28/0.15	(.011/.006)
Desired Side Play	0.20	(.008)
<b>MAIN BEARINGS</b>		
Dia. of Brg. Bore in Block	78.019/78.00	(3.0716/3.0709)
Brg. Thickness	2.484/2.471	(.0978/.0973)
*Wear Limits—Min. Thk.	2.459	(.0968)
Dia. of Main Brg. Jr.	72.974/72.944	(2.8730/2.8718)
*Wear Limits—Min. Dia.	72.918	(2.8708)
Clearance Limits	0.133/0.058	(.0052/.0023)
Desired Clearance	0.096	(.0038)
C/S End Play	0.17/0.04	(.0067/.0015)
<b>PISTON PIN</b>		
Length	71.0/70.7	(2.795/2.783)
Diameter	28.575/28.571	(1.1250/1.1248)
*Wear Limits—Min. Dia.	28.562	(1.1245)
Desired Fit	Light Push	
Bush. Hole Dia.—Fin.	28.598/28.588	(1.1259/1.1255)
*Wear Limits—Max. Dia.	28.623	(1.1269)
Pin Cl. in Bushing	0.013/0.028	(0.0005/0.0011)
Desired Pin Fit	0.020	0.0008
<b>TAPPET</b>		
Outside Dia.	25.324/25.311	(.9970/.9965)
Bore in Block	25.364/25.344	(.9986/.9978)
*Wear Limits	0.13	(.005)

<b>ENGINE MODEL</b>	<b>TM</b>	
<b>PISTONS</b>		
Cylinder Dia.	91.039/91.000	(3.5842/3.5827)
*Wear Limits—Cyl. Bore	0.20	(.008)
Piston Pin Hole Dia.	28.582/28.577	(1.1253/1.1251)
Ring Groove Width—#1	2.080/2.060	(.0819/.0811)
Max. Wear Limit Width	2.131	(.0839)
Ring Groove Width #2—	2.060/2.040	(.0811/.0803)
*Max Wear		
Limit Width #2—	2.111	(.0831)
Ring Groove Width #3	4.040/4.020	(.1590/.1583)
*Max Wear Limit Width	4.089	(.1610)
Piston Fit-Feeler Gauge	0.08	(.003)
Lbs. Pull	2.3-4.5Kg	(5-10#)
<b>PISTON RINGS</b>		
Ring Width—#1	1.990/1.960	(.078/.077)
*Wear Limits—Min. Width	1.905	(.075)
Ring Width—#2	1.990/1.960	(.078/.077)
*Wear Limits—Min. Width	1.905	(.075)
Ring Width #3	4.007/3.904	(.1578/.1537)
Wear Limits—Min. Width	3.853	(.1517)
Ring Gap Clear—#1	0.25/0.50	(.010/.020)
Ring Gap Clear—#2	0.25/0.50	(.010/.020)
Ring Gap Clear—#3	0.38/1.40	(.015/.055)
Ring Side Clear—#1	0.120/0.070	(.0047/.0028)
Ring Side Clear—#2	0.100/0.050	(.0039/.0020)
Ring Side Clear—#3	0.136/0.013	(.0054/.0005)

**NOTES**

---



---



---



---



---



---



---



---



---



---



---



---



---



---



---



---



---



---



---



---



---



---



---



---

# Index



## WARNING

Read and observe all individual safety warnings as you use this manual to operate, service or repair your engine. See pages 1 and 2.

<b>Imp rtant Safety Notice and Warnings</b> .....	1 & 2
<b>F rward</b> .....	3
<b>Continental Industrial Engines Specifications</b> .....	4
<b>SECTION 1 - General Information</b>	
Continental Overhead Valve Engine .....	5
<b>SECTION 2 - Operating Instructions</b>	
Preparation of a New Engine for Operation .....	7
Starting the Engine .....	7
Stopping the Engine .....	9
11 "Musts" for your Engines .....	9
Cold Weather Operation .....	9
Engine Preparation for Winter Use .....	10
Preparation of Engine for Seasonal Storage .....	11
<b>SECTION 3 - Lubrication</b>	
Engine Lubrication System .....	13
Oil Pump .....	13
Lubrication Recommendations .....	13
<b>SECTION 4 - Cooling System</b>	
Cooling System .....	15
Effect of Altitude on Cooling .....	16
Anti-Freezes .....	16
Cleaning Cooling System .....	16
Testing Thermostat .....	17
Radiator Pressure Cap .....	18
Fan Belt Tension .....	18
Water Pump .....	19
<b>SECTION 5 - Fuel Systems</b>	
Gravity Fuel System .....	21
Mechanical Fuel Pump .....	21
Electrical Fuel Pump .....	22
Carburetor .....	22
Teledyne Continental Carburetor .....	22
Zenith Carburetor .....	23
Carburetor Chokes .....	24
Draining Fuel from Carburetor .....	24
<b>SECTION 6 - Governors</b>	
Checking and Adjusting Mechanical - Governor Linkage .....	25
Cam Gear Governor .....	25
Constant Speed Governor .....	26
Variable Speed Governor .....	27
Hinged Lever Governor .....	27
Velocity Governor .....	28

<b>SECTION 7 - Ignition System</b>	
Electronic Ignition System	29
Ignition System Components	30
Distributor Maintenance	32
Spark Plugs	32
Distributor Ignition Timing (With Timing Light)	33
Distributor Ignition Timing (Without Timing Light)	34
Charging Circuit	35
<b>SECTION 8 - Preventive Maintenance</b>	
Daily Preventive Maintenance Schedule	39
Oil Bath Air Cleaner	40
Dry Type Replaceable Air Filter	40
PCV System	41
50 - Hour Preventive Maintenance Schedule	42
250 - Hour Preventive Maintenance Schedule	43
500 - Hour Preventive Maintenance Schedule	44
<b>SECTION 9 - Engine Repair and Overhaul</b>	
Cylinder Head	47
Valve Guides	48
Valve Seat Inserts	48
Valve Guide Data	49
Valves	50
Valve Springs	51
Rocker Arms	52
Valve Push Rods	52
Checking Bore Wear	52
Preparing Cylinder Walls for Re-Ringing or Re-Boring	52
Pistons	54
Piston Pins	54
Connecting Rod	55
Piston and Connecting Rod Assembly	55
Piston Rings	56
Recommended Method of Installing Piston Rings	56
Crankshaft and Main Bearings	57
Bearings	58
Camshaft	60
Tappets	60
Rear Crankshaft Oil Seals	60
Oil Pump	62
Timing Gears	63
Crankshaft End Play	64
Flywheel and Flywheel Housing	64
Reassembling Engine	65
Installing Oil Pan	66
Installing Head	65
<b>SECTION 10 - Trouble Shooting</b>	
Starting Motor - Will Not Crank Engine	67
Engine Cranks - But Does Not Start	67
Engine Runs with Continuous Misfiring	68
Engine Runs Unevenly	68
Engine Runs Improperly	68
Lack of Power	68
Poor Compression	68
Overheating	68
Low Oil Pressure	68
High Oil Pressure	68
High Oil Consumption	69
Engine Knocks and Other Noises	69
<b>SECTION 11 - Torque Specifications</b>	71 - 72
<b>SECTION 12 - Limits and Clearance Data</b>	73 - 74

# LIMITED ENGINE WARRANTY

**WIS-CON TOTAL POWER CORPORATION** (herein "Wis-Con"), warrants to the original retail purchaser (herein "Purchaser"), that each new Wis-Con engine or service engine assembly (herein "engine(s)") will be free from defects in material and workmanship for a period of one (1) year after delivery, or for up to 2,000 hours of operation by the Purchaser, whichever occurs first. Wis-Con's obligation under this Limited Warranty shall be limited, at Wis-Con's option, to repairing or replacing the engine, which upon examination is found to be defective in material or workmanship. The repair or replacement of any engine under this Limited Warranty shall not extend the term of the engine warranty beyond the original term as set forth above.

All repairs qualifying under this Limited Warranty must be performed by Wis-con or one of its authorized Distributors or Warranty Stations. In the event that any engine is found to be defective during the warranty period, the Purchaser shall notify Wis-Con, or one of its authorized Distributors or Warranty Stations, of any claimed defect within thirty (30) days after such defect is discovered. The engine claimed to be defective must then be promptly delivered to an authorized Distributor or Warranty Station for inspection, repair or replacement. The Purchaser is responsible for all transportation charges in connection with any covered warranty work. In connection with a covered warranty repair or replacement, Wis-Con may, in its sole discretion, assume responsibility for a portion of the labor necessary for removal and reinstallation of an engine. However, the Purchaser shall be responsible for other labor charges not assumed by Wis-Con and for all labor charges and travel expenses incurred in connection with travel to and from Purchaser's location.

This Limited Warranty shall not apply to:

- A. Defective conditions caused, in whole or in part, by an engine which has, in Wis-Con's opinion, been subjected to negligence in use, misuse, abuse, improper installation or application, improper maintenance or repair, alteration, repair or alteration by an unauthorized repair facility, over-speeding, casualty, or improper storage, transportation, or handling; and
- B. Engine tune-ups and normal maintenance service as specified in the Operator's Manual, including, but not limited to, valve adjustment, normal replacement of service items, fuel and lubricating oils, fan belts, anti-freeze, etc.

Wis-Con reserves the right to modify, alter or improve any engines without incurring any obligation to modify or replace any engines previously sold without such modification, alteration or improvement.

Written and oral representations made by Wis-Con's employees or agents, before or after sale of the engine, are not to be considered warranties or additional obligations unless they are in writing and signed by an officer or authorized employee of Wis-Con.

**THIS LIMITED WARRANTY IS THE SOLE AND ENTIRE WARRANTY PERTAINING TO WIS-CON'S ENGINES AND IS IN LIEU OF AND EXCLUDES ALL OTHER WARRANTIES OF ANY NATURE WHATSOEVER, WHETHER EXPRESS, IMPLIED OR ARISING BY OPERATION OF LAW, TRADE, USAGE OR COURSE OF DEALING, INCLUDING, BUT NOT LIMITED TO, WARRANTIES OF MERCHANTABILITY, WARRANTIES OF FITNESS FOR A PARTICULAR PURPOSE AND ANY WARRANTIES RELATING TO MATERIALS OR COMPONENTS MANUFACTURED BY ANY PARTY OTHER THAN WIS-CON. PURCHASER REPRESENTS THAT IT ALONE HAS DETERMINED THAT THE ENGINES PURCHASED ARE SUITABLE FOR AND WILL MEET THE REQUIREMENTS OF THEIR INTENDED USE.**

Limitation of Liability and Remedy. In no event, whether arising out of breach of contract, warranty or tort (including negligence, failure to warn or strict liability) or otherwise, shall Wis-Con be liable to Purchaser, or to Purchaser's officers, employees, or representatives, or to any third party, for any special, indirect, consequential or incidental damages, including, but not limited to loss of profit or revenues, loss of use of equipment or services furnished by Wis-Con, damage to associated equipment, cost of capital, cost of substitute products, facilities, service or replacement power or down-time costs. In no event shall Wis-Con's liability for any claim for any engine exceed Wis-Con's price for the engine or engine component part that gives rise to the claim. Purchaser assumes all other risks and liabilities for any loss, damage, or injury to persons, property, or the environment arising out of, connected with or resulting from the use or subsequent sale of the engines, either alone or in combination with other products. Purchaser expressly agrees that the remedies granted to it hereunder are Purchaser's sole and exclusive remedies with respect to any claim of Purchaser arising under this Limited Warranty.



**SERVICE AND PARTS**  
**Available from your Authorized**  
**WIS-CON TOTAL POWER**  
**Service Center**

**⚠ WARNING ⚠**

**California Proposition 65**

The engine exhaust from this product contains chemicals known to the State of California to cause cancer, birth defects or other reproductive harm.

10290069

**HEADQUARTERS:**

3409 Democrat Road P.O. Box 181160 Memphis, Tennessee 38181  
Phone: (901) 365-3600 TELEX: 462-1058 (ITT) FAX NO: (901) 369-4050

**EUROPEAN:**

Rue Joseph Deflandre, 13 B-4053 Chaudfontaine (Liege) Belgium  
Phone: (32) (41) 675320 TELEX: 42631 TDY TP B FAX NO: (32) (41) 677987